



TAOGLAS®



Datasheet

Taoglas Reach Series - PCS.68.A

Description:

Reach Low Profile Wideband 5G/4G PCB SMD Antenna

Features:

- Patent Pending Innovative Low Profile Design
- High Efficiency Wideband Antenna, Covering 600 to 6000 MHz
- Supporting 5G FR1 Bands
- 600 MHz 5G/4G Band 71 Support
- Surface Mount Distribution (SMD) - Supplied on Tape & Reel
- Manufactured in an IATF16949 Certified Facility
- Dimensions: 42 x 10 x 1.5 mm
- RoHS & REACH Compliant

1. Introduction	3
2. Specifications	5
3. Antenna Characteristics	7
4. Radiation Patterns	11
5. Mechanical Drawing	16
6. Antenna Integration Guide	17
7. Solder Reflow Profile	25
8. Packaging	26
<hr/>	
Changelog	27

Taoglas makes no warranties based on the accuracy or completeness of the contents of this document and reserves the right to make changes to specifications and product descriptions at any time without notice. Taoglas reserves all rights to this document and the information contained herein. Reproduction, use or disclosure to third parties without express permission is strictly prohibited.



1. Introduction



The Taoglas Reach Series PCS.68.A is a revolutionary 5G/4G, low profile, small footprint, patent pending, SMD mount PCB wide-band antenna. The PCS.68.A has been designed to cover all 5G and 4G bands, including all sub-6GHz deployments across the 600MHz to 6000MHz spectrum in a very small footprint of just 42 x 10mm. It also covers 3G/ 2G bands to allow for fall-back when 5G/4G is not available. The low profile size of just 1.5mm in height allows for installation where height is at a premium.

Typical applications include

- Autonomous/UAVs
- Smart Metering
- Connected Health
- Wearable Technologies
- Payment Terminals

The patent pending design uses printed circuit board material and innovative design techniques to deliver the highest efficiencies at all bands when mounted on the device's main PCB. The PCS.68.A is suitable for lower cost 5G/4G applications, especially IoT projects requiring wide bandwidth and comes supplied on tape and reel to allow it to be mounted via 'pick & place' onto the PCB.

If tuning is required, it can also be tuned specifically depending on device environment. Contact your local Taoglas customer support team for advice on integrating the PCS.68.A into your device.

1.1 Key Advantages

1. Highest efficiency in small footprint

A comparative antenna to the Reach, for example, metal/ceramic/FPC, would have much-reduced efficiency in this configuration due to their high substrate loss at high frequencies. Very high efficiency antennas are critical to 5G/4G devices ability to deliver the stated data-speed rates of systems such as 5G /4G.

2. Low profile

Many applications require a large mechanical size to work efficiently, which occupies the usable PCB space. The size of PCS.68 is only 42mm X 10mm (420mm²), and if accounting for the 4mm keep out area, the total area consumed on the PCB is only 42mmX14mm = 588mm². The solution allows board designers to maximize their PCB space.

3. Adaptable

The high radiation efficiency of the Reach over its entire operating bandwidth means that the total efficiency is only limited by the impedance mismatch loss. As a result, this antenna has been optimized via a matching network to 600MHz – 960MHz and 1710MHz – 6000MHz with the minimum efficiencies of 30% and 50% respectively. The performance of direct feeding the antenna without a matching circuit is good from 730MHz – 960MHz and 1710MHz – 6000MHz.

4. More resistant to detuning compared to other antenna integrations

If tuning is required it can be tuned for the device environment using a matching circuit, or other techniques on the main PCB itself. There is no need for new tooling, thereby saving money if customization is required.

5. Surface Mount Device (SMD)

Direct mount, 'on-board' antennas save on labor, cable and connector costs, lead to higher integration yield rates and reduce losses in transmission.

6. Minimum Transmission and Reception Losses

These are kept to an absolute minimum resulting in much improved OTA (over the air), i.e. TRP (Total Radiated Power) / TIS (Total Isotropic Radiation), device performance compared to similar efficiency cable and connector antenna solutions. This means it is an ideal antenna to be used for devices that This means it is an ideal antenna to be used for devices that need to pass for example USA carrier network approvals.

2. Specifications

Electrical								
Band	Frequency (MHz)	Efficiency (%)	Average Gain (dB)	Peak Gain (dBi)	VSWR	Impedance	Polarization	Radiation Pattern
5G NR/4G Band 5,8,12,13,14,17,18,20, 26,27,28, 29,71	617~960	45	-3.3	-1	<3.5:1	50 Ω	Linear	Omni
5G NR/4G Band 21,32,74,75,76	1427~1518	25	-7	-2				
4G/3G Band 1,2,3,4,9,23,25,35,39,66	1710~2200	77	-1.2	3.8				
Wi-Fi 2400	2400~2500	53	-2.7	2				
4G/3G Band 7,38,41	2490~2690	62	-2.2	4				
5G NR/4G Band 22,42,43,48,77,78,79	3300~5000	67	-2	4.5				
LTE5200/ Wi-Fi 5800	5150~5925	77	-1	4				

The PCS.86.A antenna performance was measured on a 130 x 42 ground plane

Mechanical	
Dimensions	42mm x 10mm x 1.5mm
Weight	2g
Material	PCB
Termination	Solder Pad
EVB Connector	SMA-Female

Environmental	
Operation Temperature	-40°C to 85°C
Storage Temperature	-40°C to 105°C
Moisture Sensitivity Level (MSL)	3 (168 Hours)
Relative Humidity	Non-condensing 65°C 95% RH
RoHs & REACH Compliant	Yes

5G/4G Bands			
Band Number	5G NR / FR1 / LTE / LTE-Advanced / WCDMA / HSPA / HSPA+ / TD-SCDMA		
	Uplink	Downlink	Covered
1	UL: 1920 to 1980	DL: 2110 to 2170	✓
2	UL: 1850 to 1910	DL: 1930 to 1990	✓
3	UL: 1710 to 1785	DL: 1805 to 1880	✓
4	UL: 1710 to 1755	DL: 2110 to 2155	✓
5	UL: 824 to 849	DL: 869 to 894	✓
7	UL: 2500 to 2570	DL: 2620 to 2690	✓
8	UL: 880 to 915	DL: 925 to 960	✓
9	UL: 1749.9 to 1784.9	DL: 1844.9 to 1879.9	✓
11	UL: 1427.9 to 1447.9	DL: 1475.9 to 1495.9	✓
12	UL: 699 to 716	DL: 729 to 746	✓
13	UL: 777 to 787	DL: 746 to 756	✓
14	UL: 788 to 798	DL: 758 to 768	✓
17	UL: 704 to 716	DL: 734 to 746	✓
18	UL: 815 to 830	DL: 860 to 875	✓
19	UL: 830 to 845	DL: 875 to 890	✓
20	UL: 832 to 862	DL: 791 to 821	✓
21	UL: 1447.9 to 1462.9	DL: 1495.9 to 1510.9	✓
22	UL: 3410 to 3490	DL: 3510 to 3590	✓
23	UL: 2000 to 2020	DL: 2180 to 2200	✓
24	UL: 1625.5 to 1660.5	DL: 1525 to 1559	✓
25	UL: 1850 to 1915	DL: 1930 to 1995	✓
26	UL: 814 to 849	DL: 859 to 894	✓
27	UL: 807 to 824	DL: 852 to 869	✓
28	UL: 703 to 748	DL: 758 to 803	✓
29	UL: -	DL: 717 to 728	✓
30	UL: 2305 to 2315	DL: 2350 to 2360	✓
31	UL: 452.5 to 457.5	DL: 462.5 to 467.5	✗
32	UL: -	DL: 1452 – 1496	✓
35		1850 to 1910	✓
38		2570 to 2620	✓
39		1880 to 1920	✓
40		2300 to 2400	✓
41		2496 to 2690	✓
42		3400 to 3600	✓
43		3600 to 3800	✓
48		3550 to 3700	✓
66	UL: 1710-1780	DL: 2110-2200	✓
71		617 to 698	✓
74/75/76		1427 to 1518	✓
77		3300 to 4200	✓
78		3300 to 3800	✓
79		4400 to 5000	✓
85	698-716	728-746	✓

3. Antenna Characteristics

3.1 Test Setup

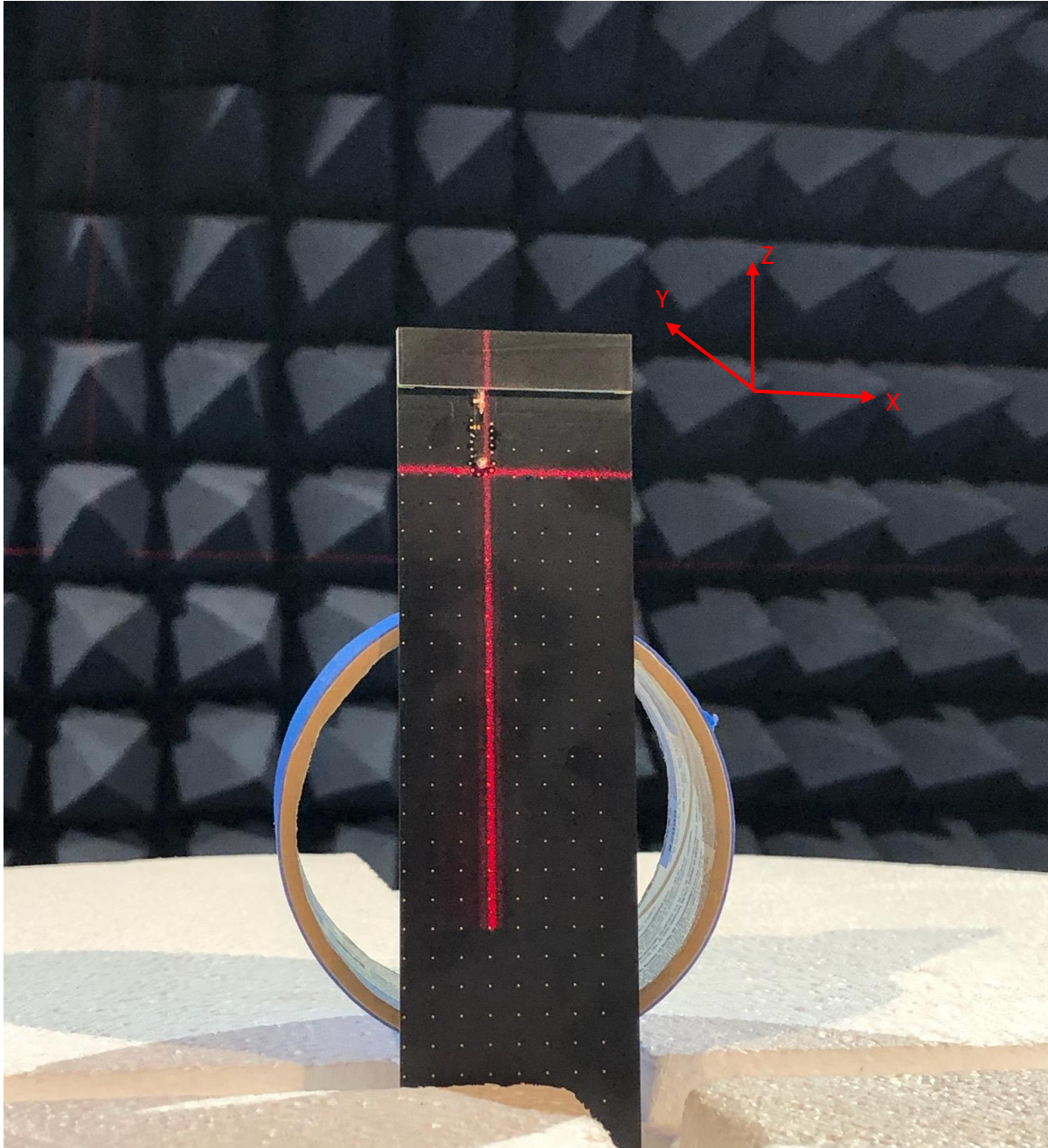

On Evaluation Board

3.2 Return Loss

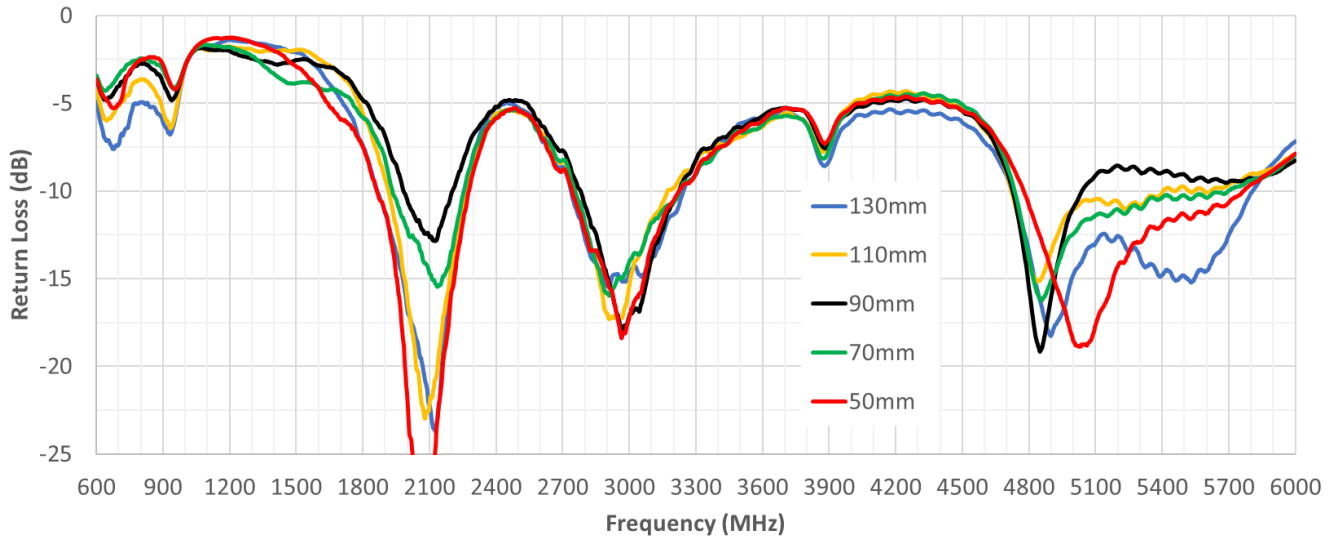

Analysis of the effect of reducing ground plane length

3.3 VSWR

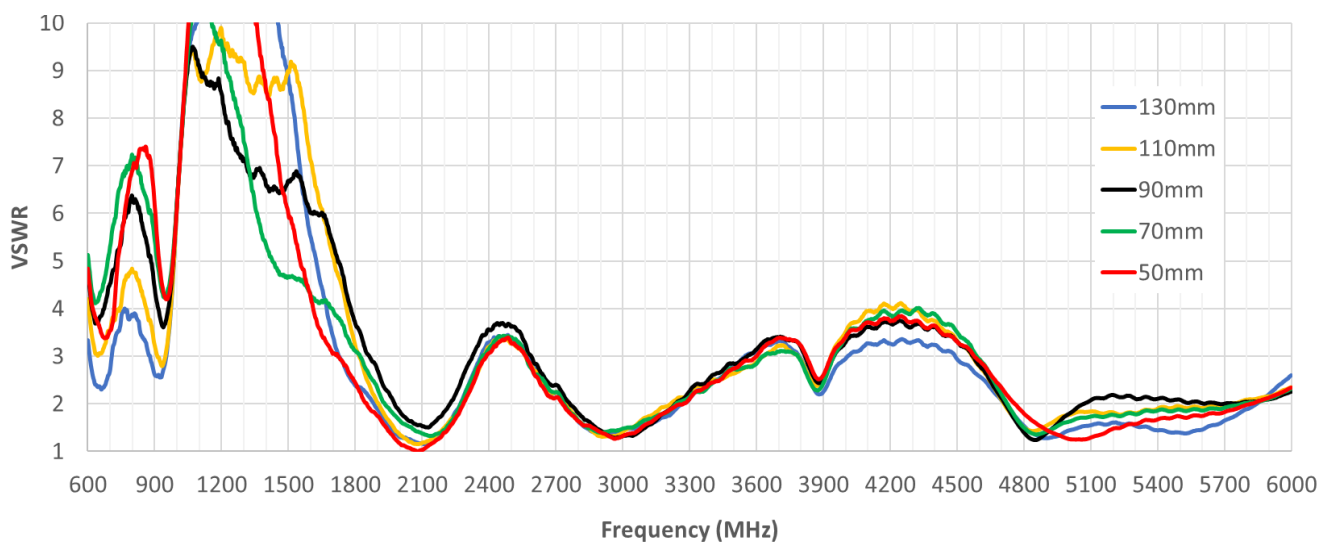

Analysis of the effect of reducing ground plane length

3.4 Efficiency

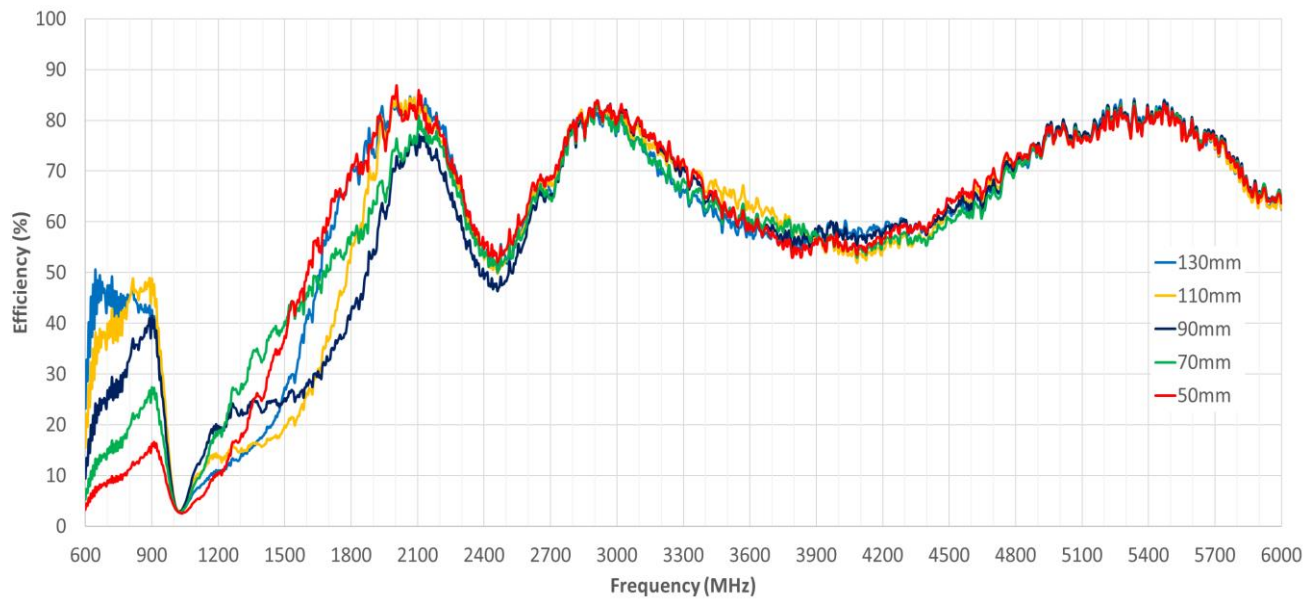

Analysis of the effect of reducing ground plane length

3.5 Peak Gain

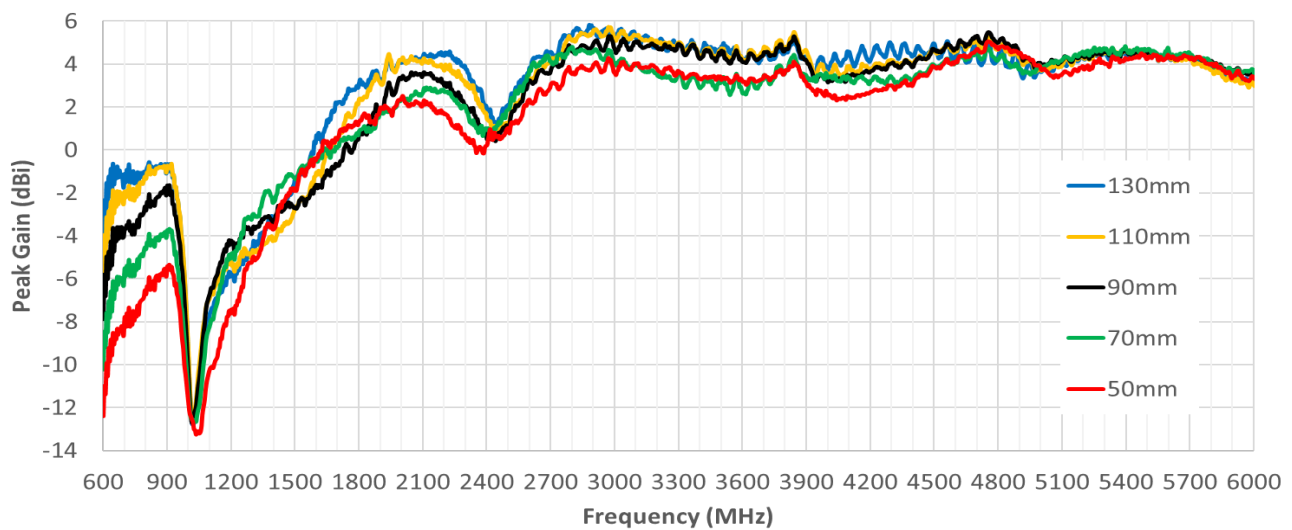

Analysis of the effect of reducing ground plane length

3.6 Average Gain

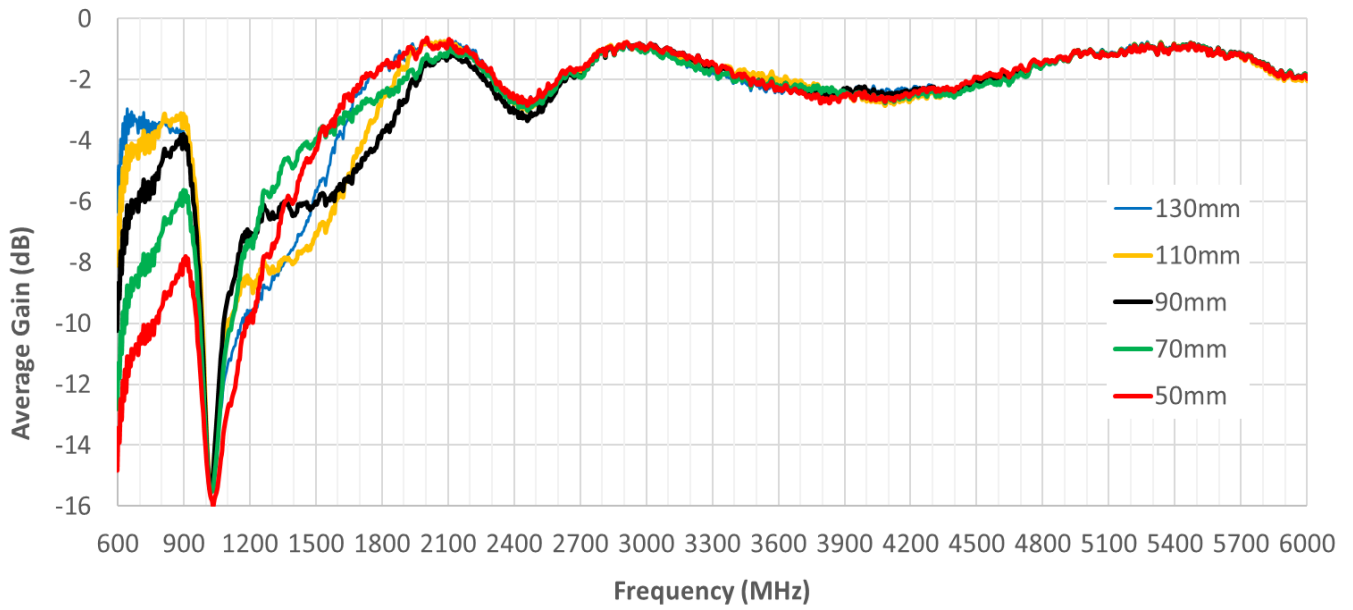

Analysis of the effect of reducing ground plane length

4. Radiation Patterns (Measured on 130 X 42mm EVB)

4.1 800MHz 3D and 2D Radiation Patterns

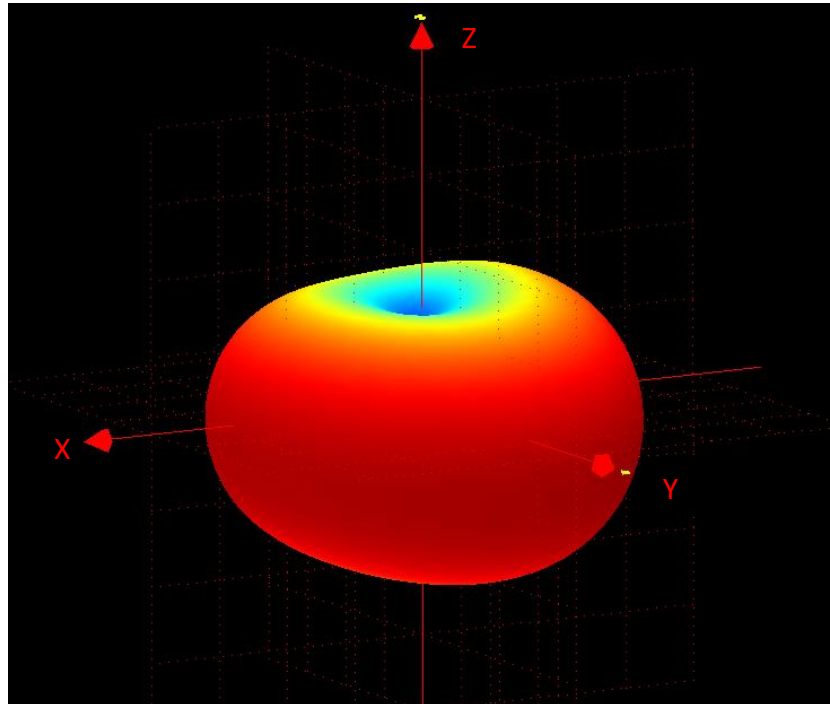

XY Plane

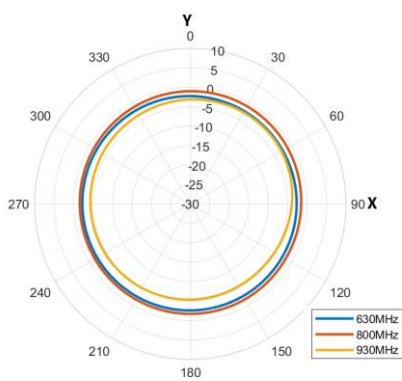

XZ Plane

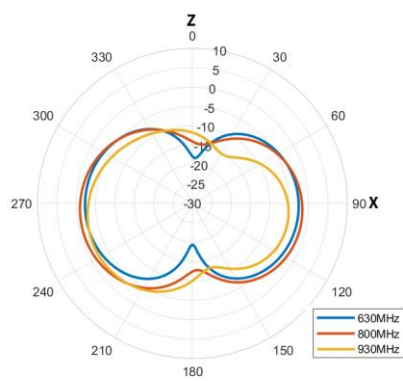

YZ Plane

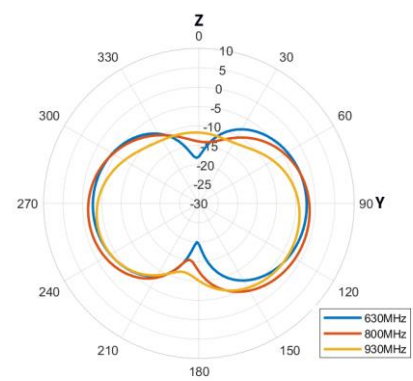

4.2 1470MHz 3D and 2D Radiation Patterns

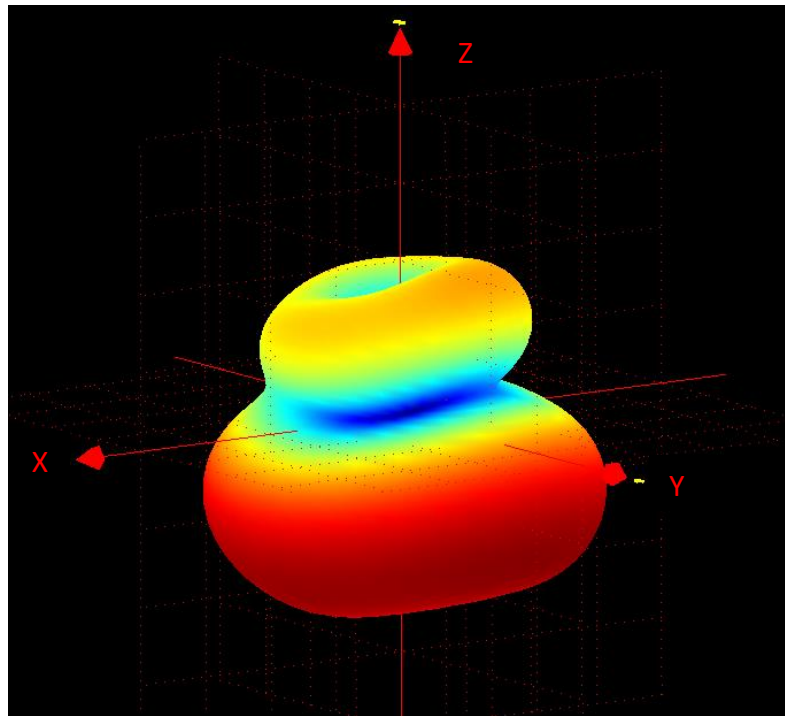

XY Plane XZ Plane YZ Plane

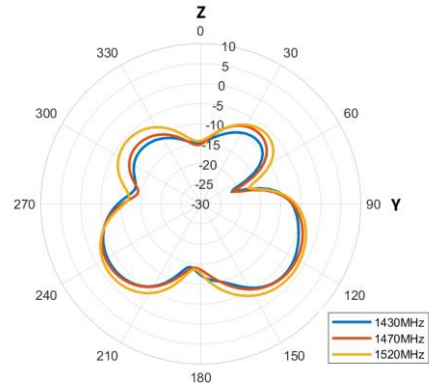
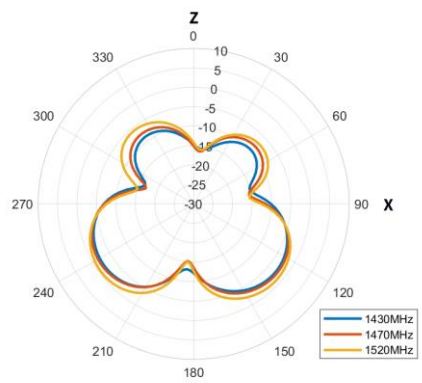
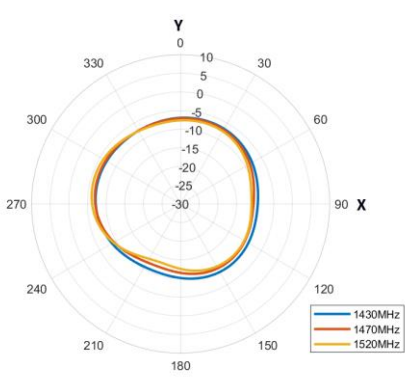

4.3 1910MHz 3D and 2D Radiation Patterns

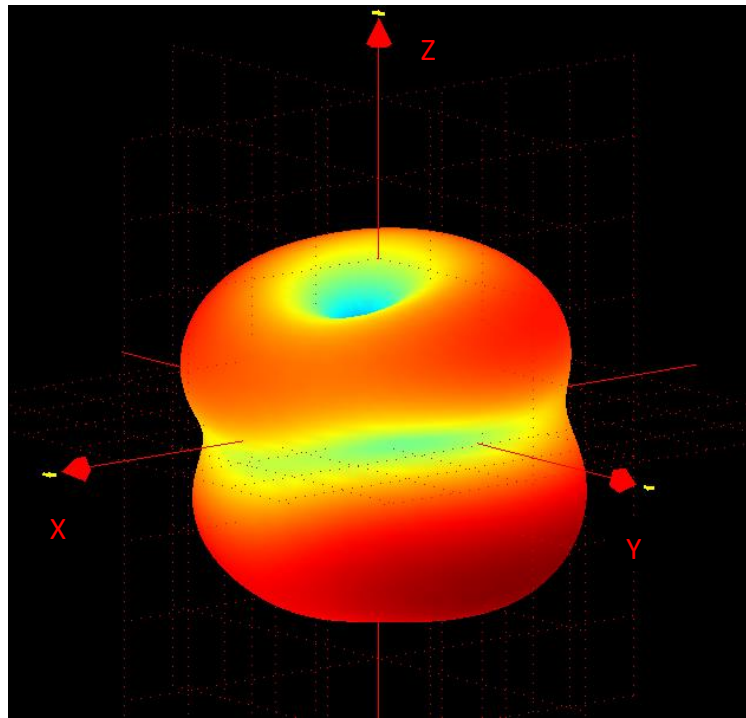

XY Plane

XZ Plane

YZ Plane

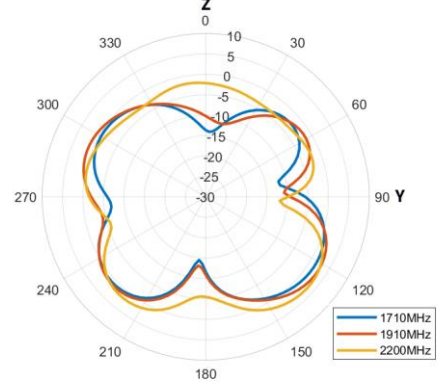
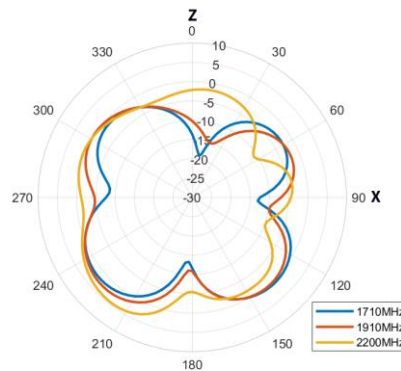
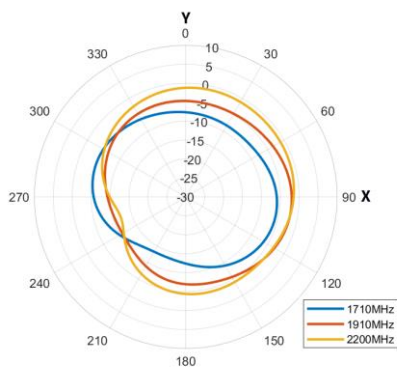

4.4 2550MHz 3D and 2D Radiation Patterns

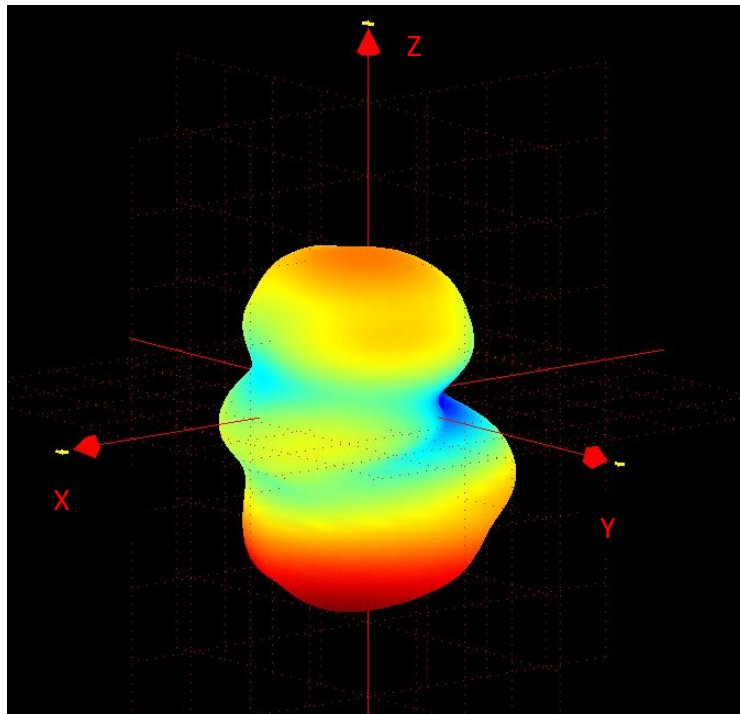

XY Plane

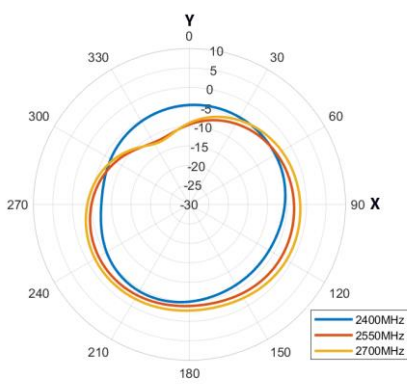

XZ Plane

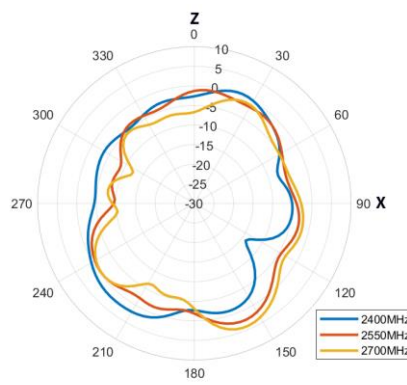

YZ Plane

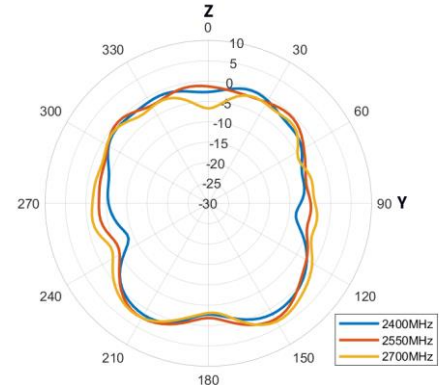

4.5 4500MHz 3D and 2D Radiation Patterns

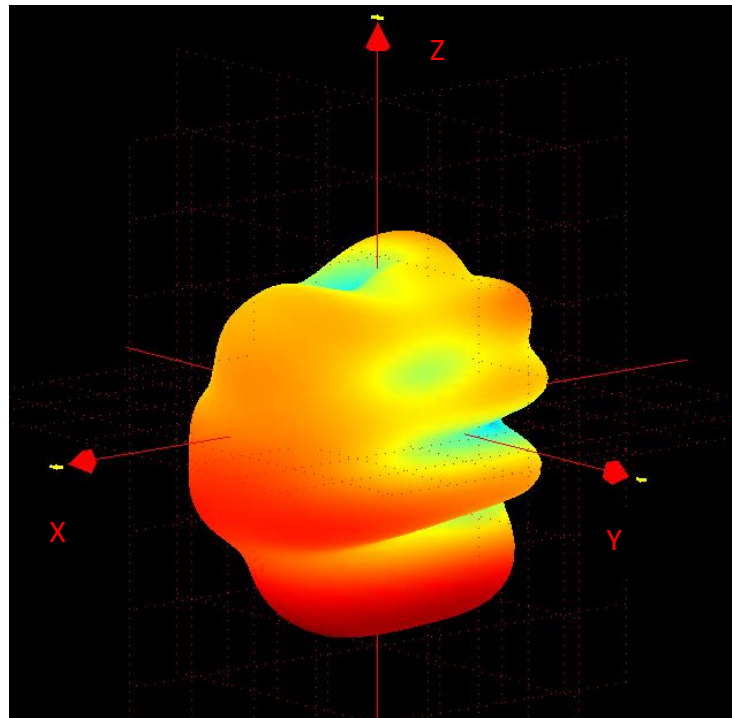



XY Plane

XZ Plane

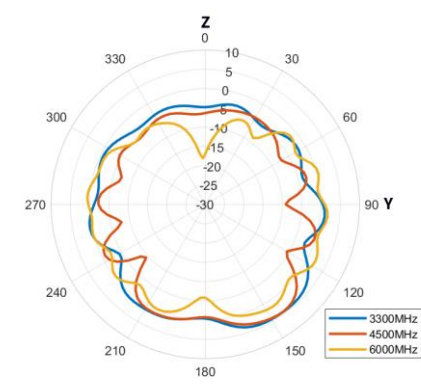
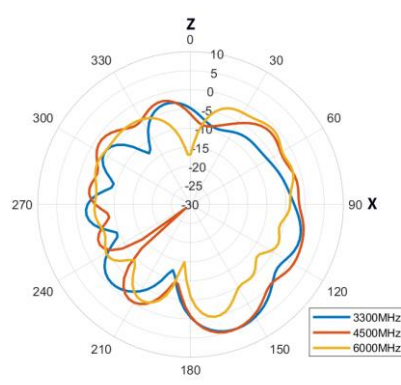
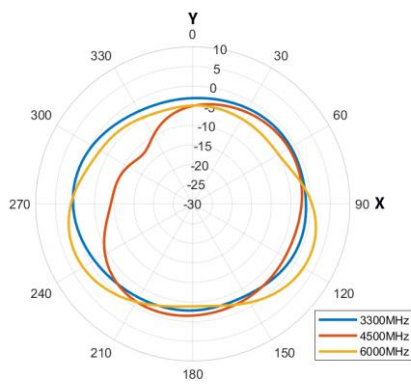
YZ Plane



5. Mechanical Drawing (Units: mm)

 ANTENNA PADS
 FOOTPRINT PADS

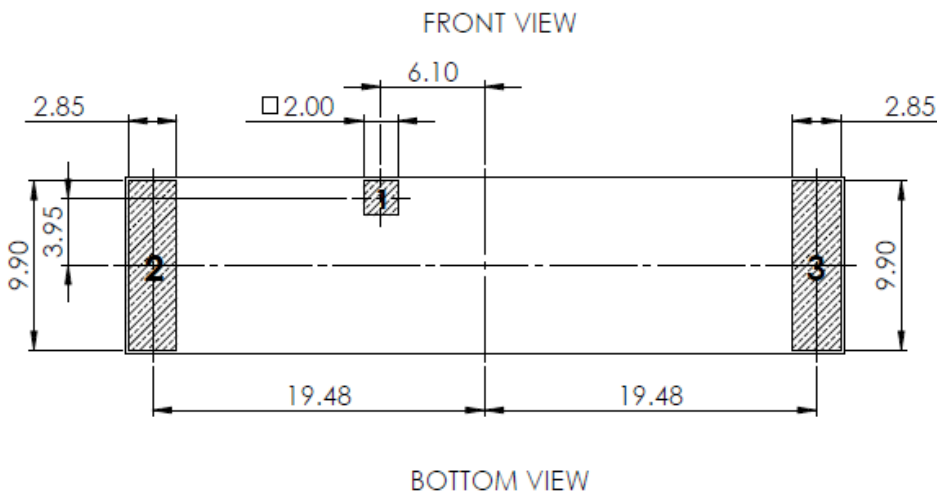
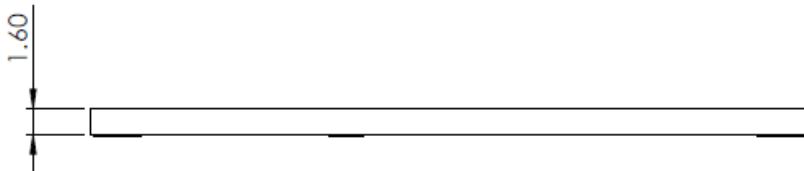
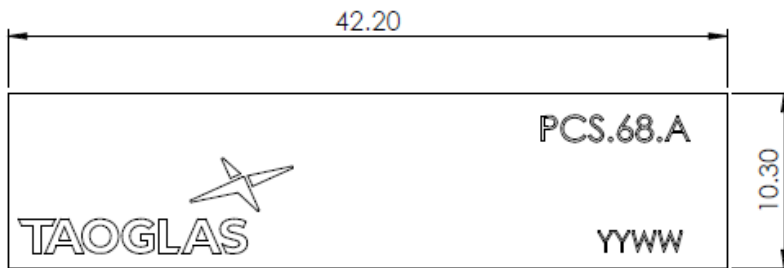
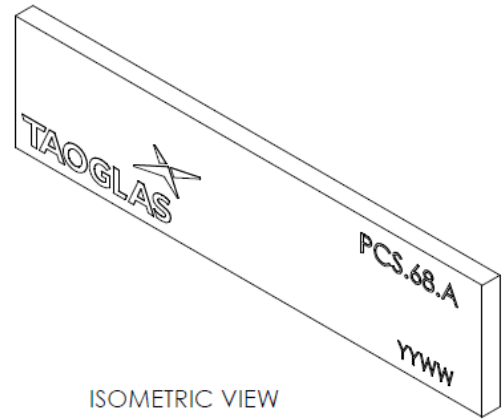

6. Antenna Integration Guide

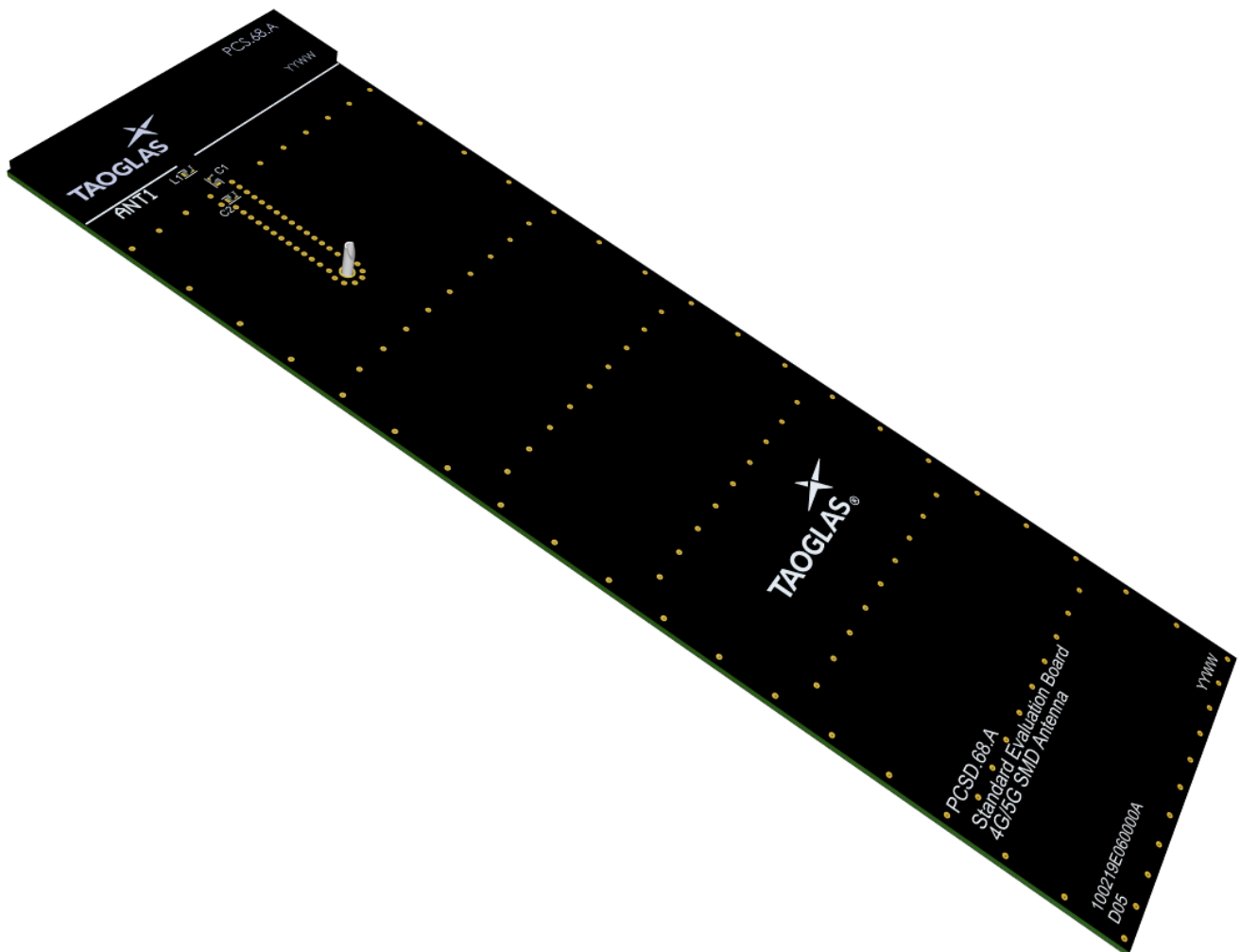
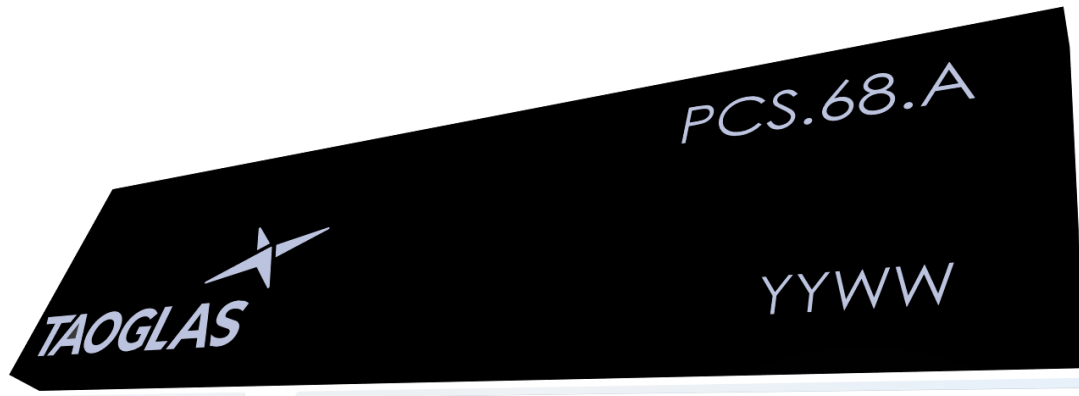

6.1 Schematic Symbol and Pin Definition

The circuit symbol for the antenna is shown below. The antenna has 3 pins with only one pin (Pin 1) as functional. Pins 2 and 3 are for mechanical strength.

Pin	Description
1	RF Feed
2,3	Mechanical, Not Connected

PCS.68.A
ANT1

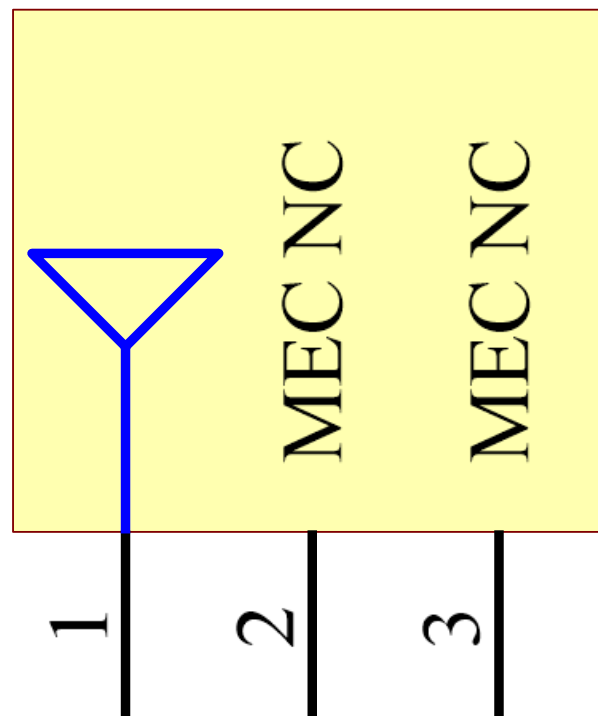

Please note you can download the CST simulation files from the website here:

<https://www.taoglas.com/product/pcs-68-a-wideband-5g-4g-pcb-smd-antenna/>

6.2 Antenna Integration

Whatever the size of the PCB, the antenna should ideally be placed on the PCB's shortest side, to take advantage of the ground plane. Optimized matching components can be placed as shown.

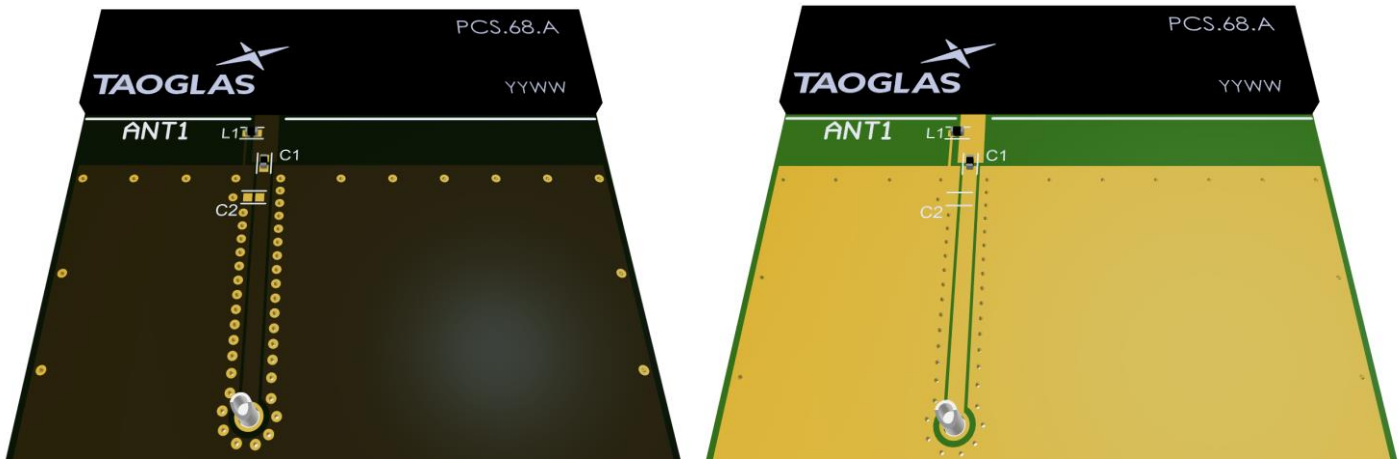

6.3 PCB Layout

The footprint and clearance on the PCB must meet the antenna specification. An example of the PCB layout shows the antenna footprint with clearance. Note the placement of the optimized components. L1 is positioned outside the ground plane and C1 is sitting across the ground plane and the copper clearance area. C2 is optional as a component but it is recommended to include these pads in case they are needed.

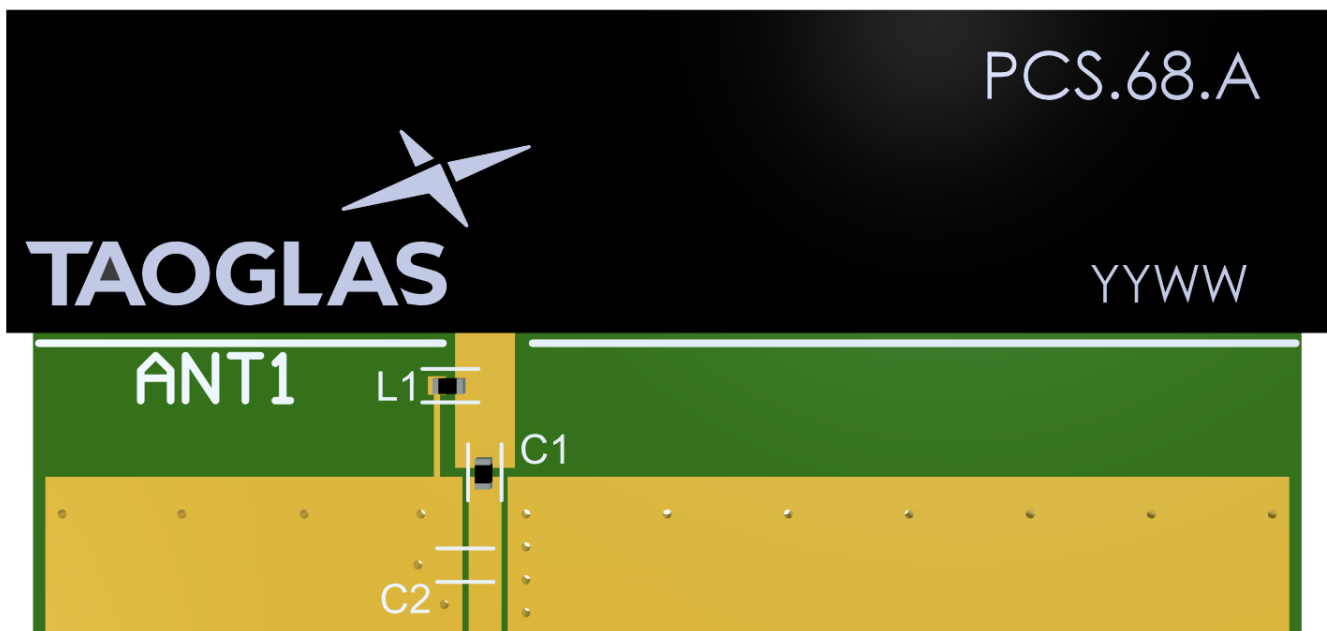

Topside

6.4 PCB Layout

The footprint and clearance on the PCB must meet the antenna specification. An example of the PCB layout shows the antenna footprint with clearance. Note the placement of the optimized components. L1 is positioned outside the ground plane and C1 is sitting across the ground plane and the copper clearance area. C2 is optional as a component but it is recommended to include these pads in case they are needed.



6.5 PCB Clearance

Below shows the antenna footprint and clearance through ALL layers on the PCB. Only the antenna pads and connections to feed and GND are present within this clearance area (marked RED). The clearance area extends to 5mm from the antenna mechanical pads to the ground area. This clearance area includes the bottom side and ALL internal layers on the PCB.

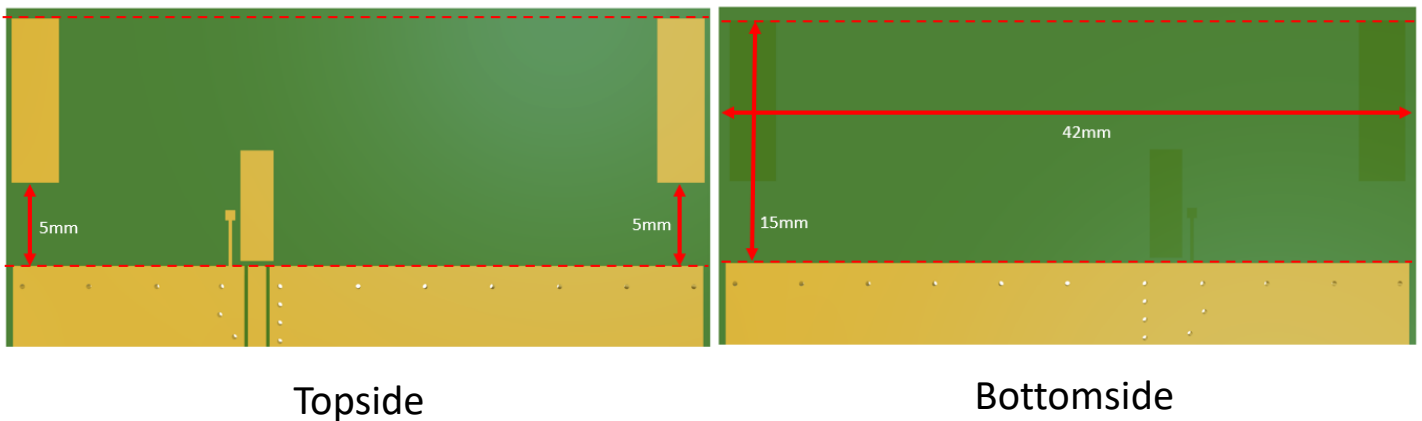

6.6 Evaluation Board



Topside

Bottomside

6.7 Evaluation Board Ground Plane Length



Ground Plane Length
130 mm

6.8 Evaluation Board Matching Circuit

A matching component (L1) in parallel with the PCS.06.A is required for the antenna to have optimal performance on the evaluation board, located outside of the ground plane in the space specified in the above images. C1 is also required as a matching component for this antenna. C1 is positioned sitting across the ground plane as shown in the above images. Additional matching components may be necessary for your device, so we recommend incorporating extra component footprints, forming a “pi” network, between the cellular module and the edge of the ground plane.

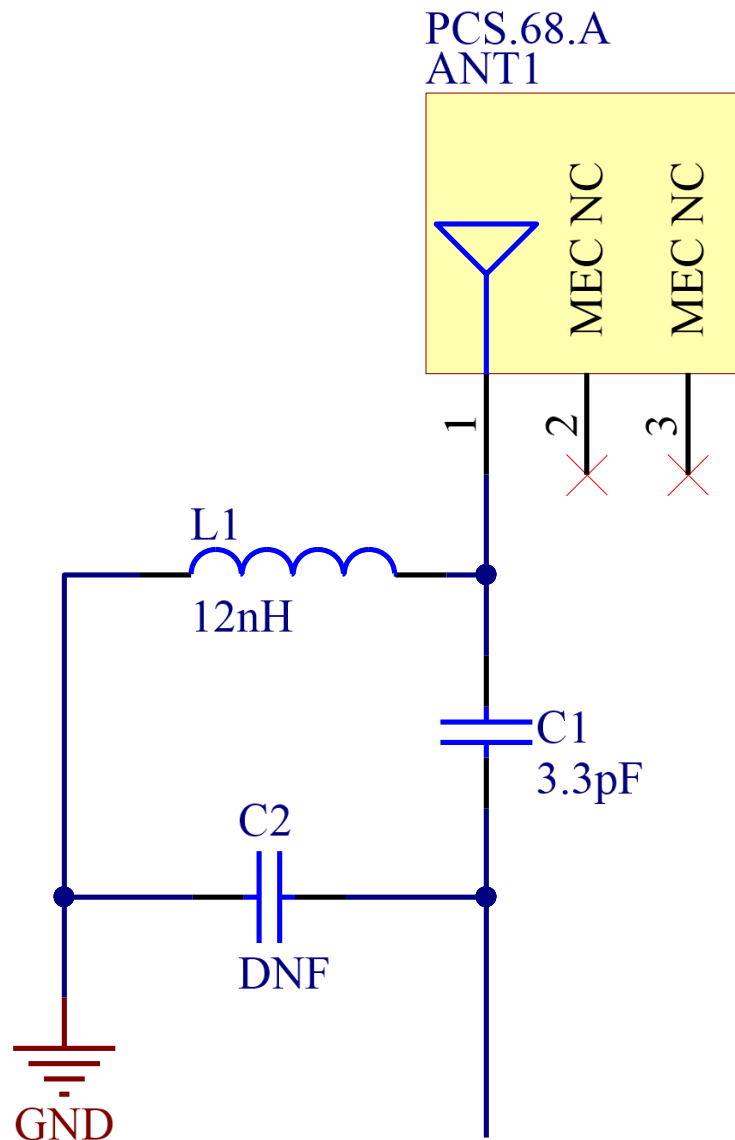

Designator	Type	Value	Description
L1	Inductor	12nH	TDK: MLK1005S Series
C1	Capacitor	3.3pF	Murata:GRM1555 Series
C2	Capacitor	Not Fitted	

6.9 Footprint

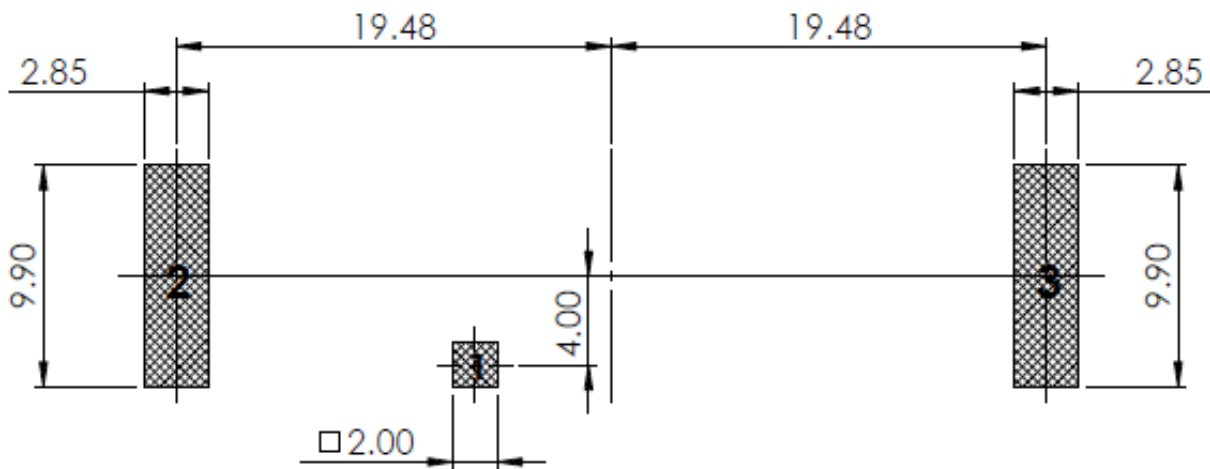

PCB FOOTPRINT

PIN:	DESCRIPTION:
1	Feed (50 ohm)
2,3	NC

7. Solder Reflow Profile

The PCS.68.A can be assembled by following the recommended soldering temperatures are as follows:

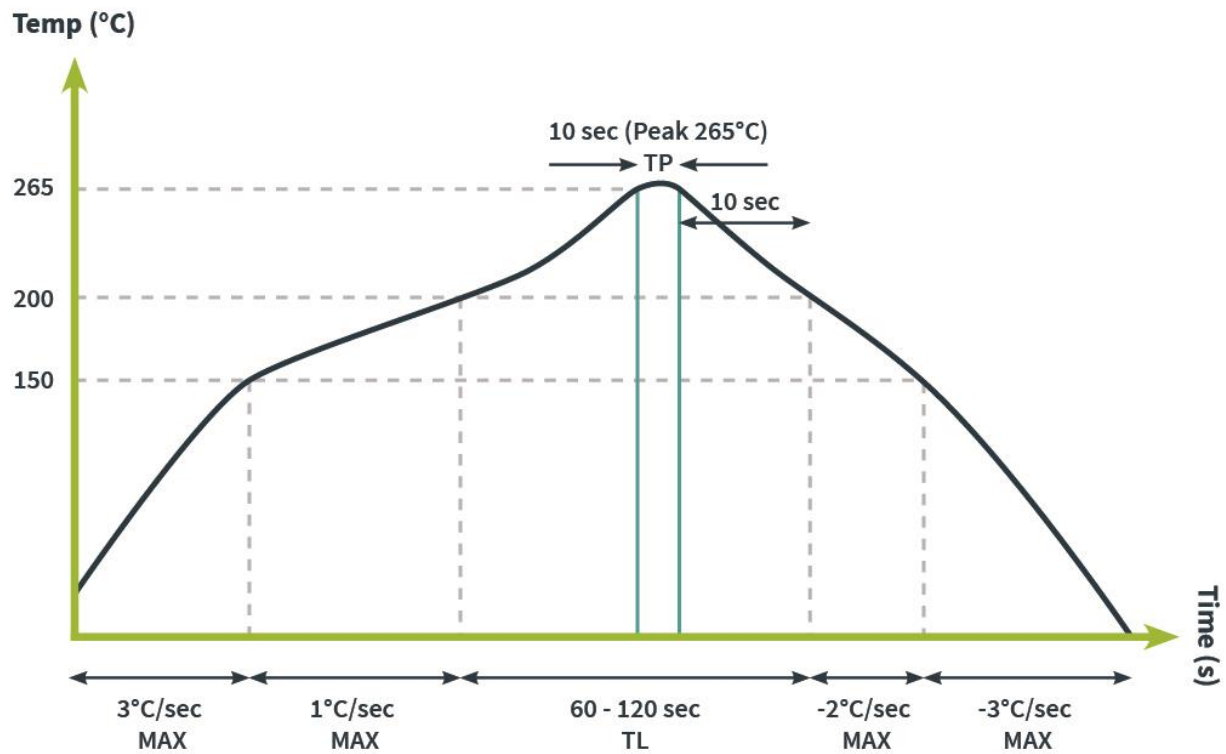

*Temperatures listed within a tolerance of +/- 10⁰ C

The PCS.68.A is not limited to the number of passes through the reflow process. Smaller components are typically mounted on the first pass, however, we do advise mounting the PCS.68.A when placing larger components on the board during subsequent reflows.

8. Packaging

800 pcs PCS.68.A per Tape & Reel
 Dimensions: 330*330*60mm
 Weight: 2.5Kg

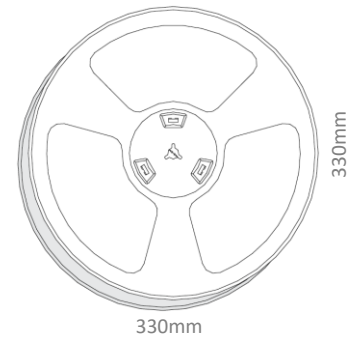
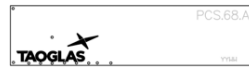

1 reel in small inner box
 Dimensions: 350*350*70mm
 Weight: 2.6Kg

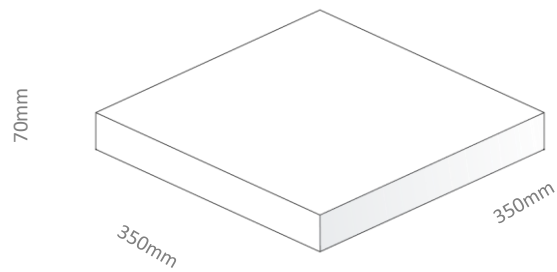

2400 pcs in one carton
 Dimensions: 370*360*275mm
 Weight: 8Kg

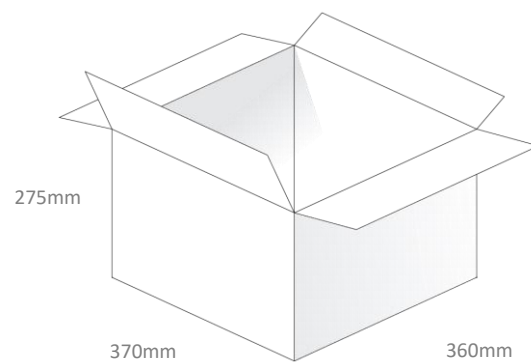

Pallet Dimensions:
 1200*1320*1000mm
 24 Cartons Per Pallet
 6 Cartons Per Layer
 4 Layers

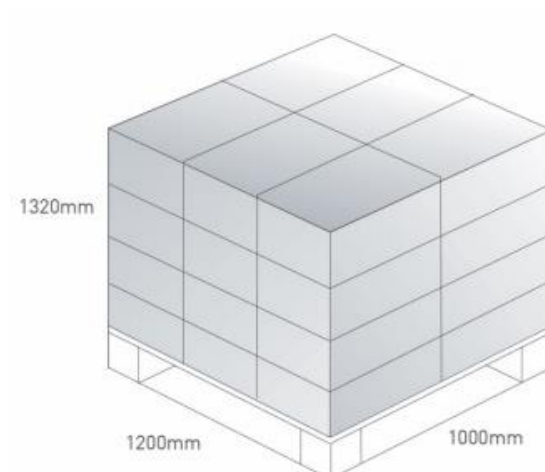

Changelog for the datasheet

SPE-19-8-129 – PCS.68.A

Revision: F (Current Version)

Date:	2021-11-03
Notes:	Integration Guide Added.
Author:	Gary West

Previous Revisions

Revision: E

Date:	2021-09-27
Notes:	Updated MSL information and fixed formatting.
Author:	Erik Landi

Revision: D

Date:	2020-03-06
Notes:	Updated drawing and pictures
Author:	Jack Conroy

Revision: C

Date:	2020-01-02
Notes:	Updated Packaging
Author:	Jack Conroy

Revision: B

Date:	2019-12-11
Notes:	Updated Packaging
Author:	Jack Conroy

Revision: A (Original Release)

Date:	2019-10-17
Notes:	Initial Datasheet Release
Author:	Yu Kai Yeung



TAOGLAS®

www.taoglas.com

