



# TAOGLAS®



# Datasheet

## GPS/GLONASS/Galileo SMD Patch Antenna

**Part No:**  
SGGP.18.4.A.08

**Description:**  
18\*18\*4mm GPS/GLONASS/Galileo SMD Patch Antenna

### Features:

- SMD Direct Mount Ceramic Patch Antenna
- GPS/Galileo/GLONASS Antenna
- GPS L1/Galileo E1 (1575.42 MHz) – 78% Efficiency
- GLONASS L1 (1602 MHz) – 80% Efficiency
- Dimensions: 18\*18\*4mm
- RoHS & Reach Compliant

1. Introduction	3
2. Specifications	4
3. Antenna Characteristics	5
4. Radiation Patterns	7
5. Mechanical Drawing	10
6. Antenna Integration Guide	11
7. Packaging	19
<hr/>	
8. Soldering Recommendations	21
<hr/>	
Changelog	22

Taoglas makes no warranties based on the accuracy or completeness of the contents of this document and reserves the right to make changes to specifications and product descriptions at any time without notice. Taoglas reserves all rights to this document and the information contained herein.

Reproduction, use or disclosure to third parties without express permission is strictly prohibited.

Copyright © Taoglas Ltd.



## 1. Introduction



The Taoglas SGGP.18 is a ceramic GPS/GLONASS/Galileo passive patch antenna designed for optimal performance on GPS L1/Galileo E1 band (1575.42 MHz) and GLONASS L1 band (1602 MHz). With a low-profile thickness of just 4mm and convenient mounting via standard SMD process, it is ideal for high-volume, low-cost assembly applications. SGGP.18 is designed for applications in navigation devices, vehicle tracking/fleet management systems, and telematics devices. It is an excellent choice for applications in transportation, defense, marine, agriculture, and navigation industries.

This antenna has been tuned for use on a 50mm\*50mm ground plane to achieve 2.86 dBi gain at 1575.42 MHz and 3.04 dBi gain at 1602 MHz. In addition to excellent efficiency, it also offers a broadly hemispherical radiation pattern with stable gain across elevations.

SGGP.18 is manufactured and tested in an IATF16949 first tier automotive approved facility. For further optimization to customer-specific device environments, custom tuned patch antennas can be supplied, subject to NRE and MOQ.

For further information or support with integrating this antenna into your device, please contact your regional Taoglas customer support team.

## 2. Specifications

GNSS Frequency Bands Covered							
<b>GPS/QZSS</b>	L1 1575.42MHz	L2 1227.6MHz	L5 1176.45MHz	L6 1278.75MHz			
	■	□	□	□			
<b>GLONASS</b>	L5R 1176.45MHz	L3PT 1201.5MHz	L2PT 1246MHz	L1CR 1575.42MHz	L1PT 1602MHz		
	□	□	□	■	■		
<b>Galileo</b>	E5a 1176.45MHz	E5b 1201.5MHz	E4 1215MHz	E3 1256MHz	E6 1278.75MHz	E2 1561MHz	E1 1575.42MHz
	□	□	□	□	□	□	■
<b>BeiDou</b>	B1 1561MHz	B2 1207.14MHz	B3 1268.52MHz				
	□	□	□				
<b>Compass</b>	E5B(B2)/ E6(B3) 1268.56MHz	E2(B1) 1561MHz					
	□	□					
<b>SBAS</b>	Omnistar 1542.5MHz	WAAS/EGN OS 1575.42MHz					
	□	■					

GNSS Electrical		
Application Bands	GPS/Galileo	GLONASS
Operation Frequency (MHz)	1575.42 ±1.023	1602±5
Return Loss (dB)	< -10	< -10
Efficiency (%)	78	80
Average Gain (dB)	-1.07	-0.98
Peak Gain (dBi)	2.86	3.04
Impedance	50 ohms	
Polarization	RHCP	
Mechanical		
Ceramic Dimension	18*18*4mm	
Weight	5.8g	
Environmental		
Operation Temperature	-40°C to 85°C	
Humidity	Non-condensing 65°C 95% RH	
Moisture Sensitivity Level (MSL)	3 (168 Hours)	

\*Measurements tested on 50\*50mm ground plane

### 3. Antenna Characteristics

#### 3.1 Return Loss

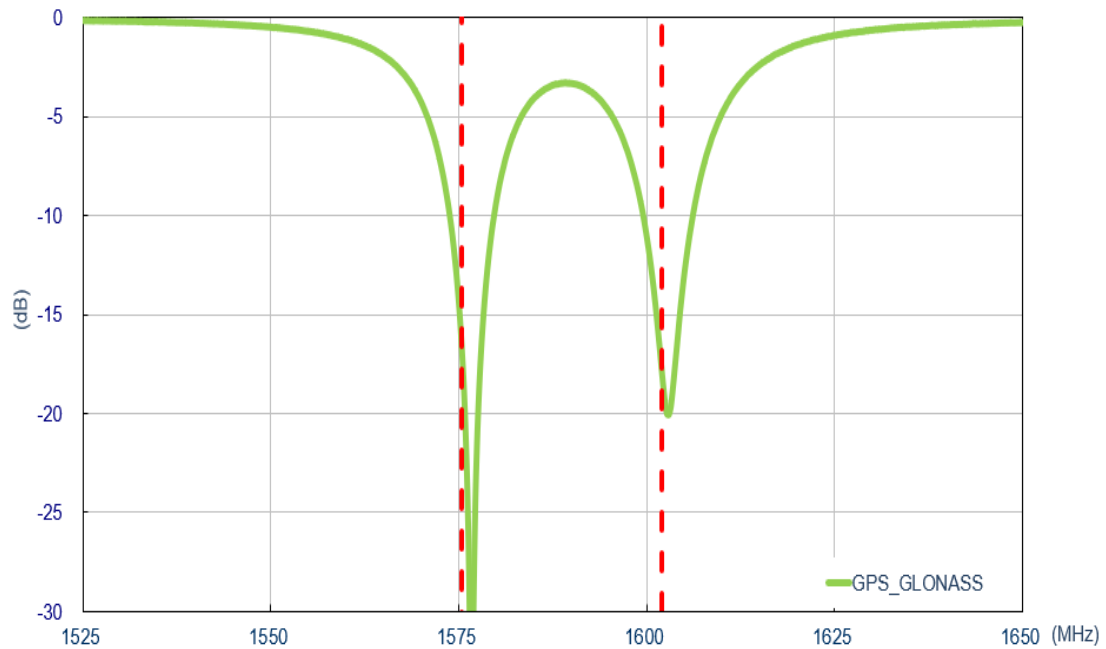

#### 3.2 Efficiency

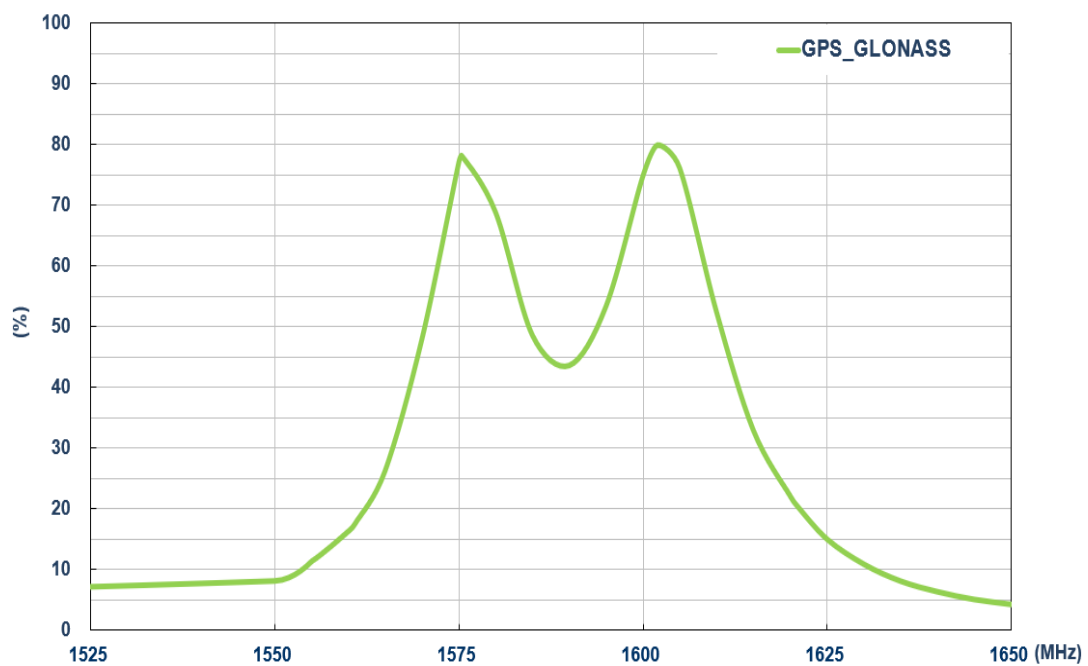

### 3.3 Average Gain

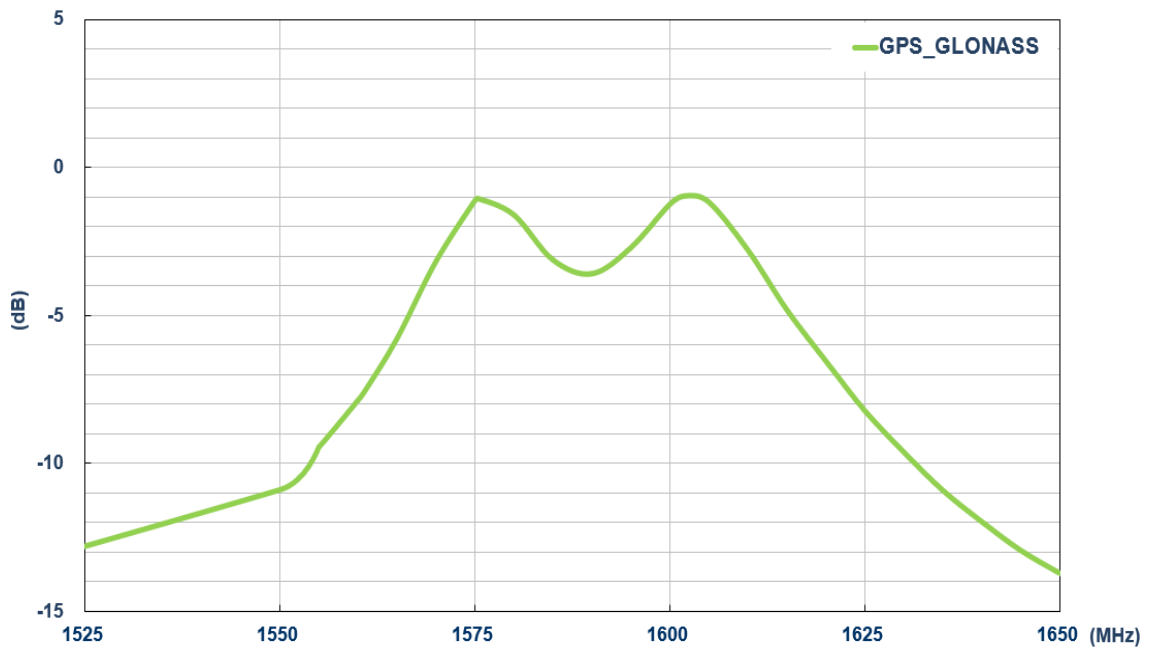

### 3.4 Peak Gain

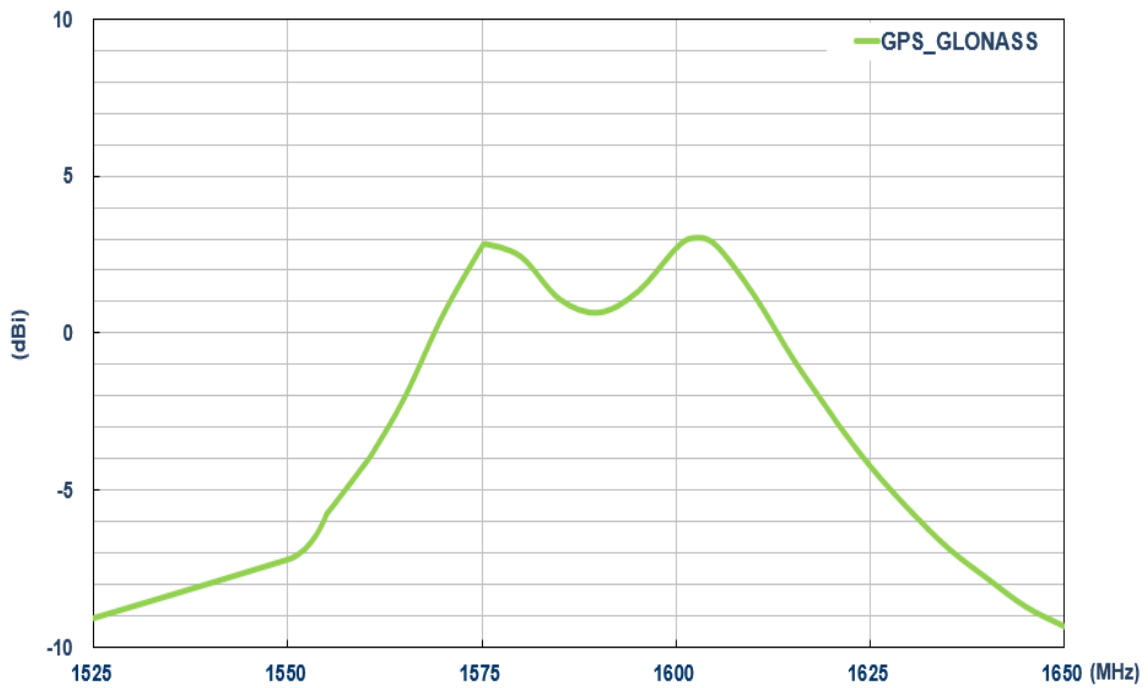

## 4. Radiation Patterns

### 4.1 Test Setup

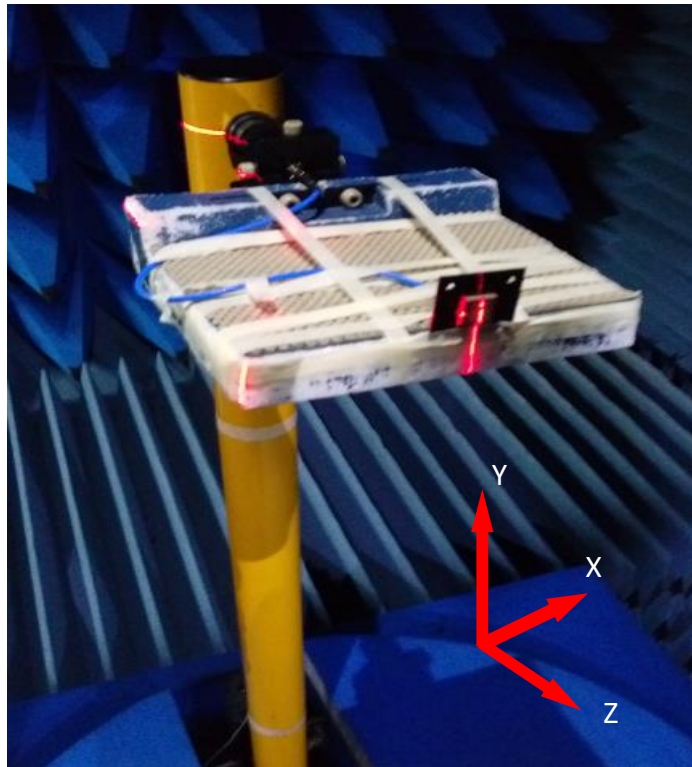

The SGGP.18.4.A.08 antenna is tested with 50mm\*50mm ground plane in a CTIA certified ETS-Lindgren Anechoic Chamber. The test setup is shown above.

4.2 1575.42MHz 3D and 2D Radiation Patterns

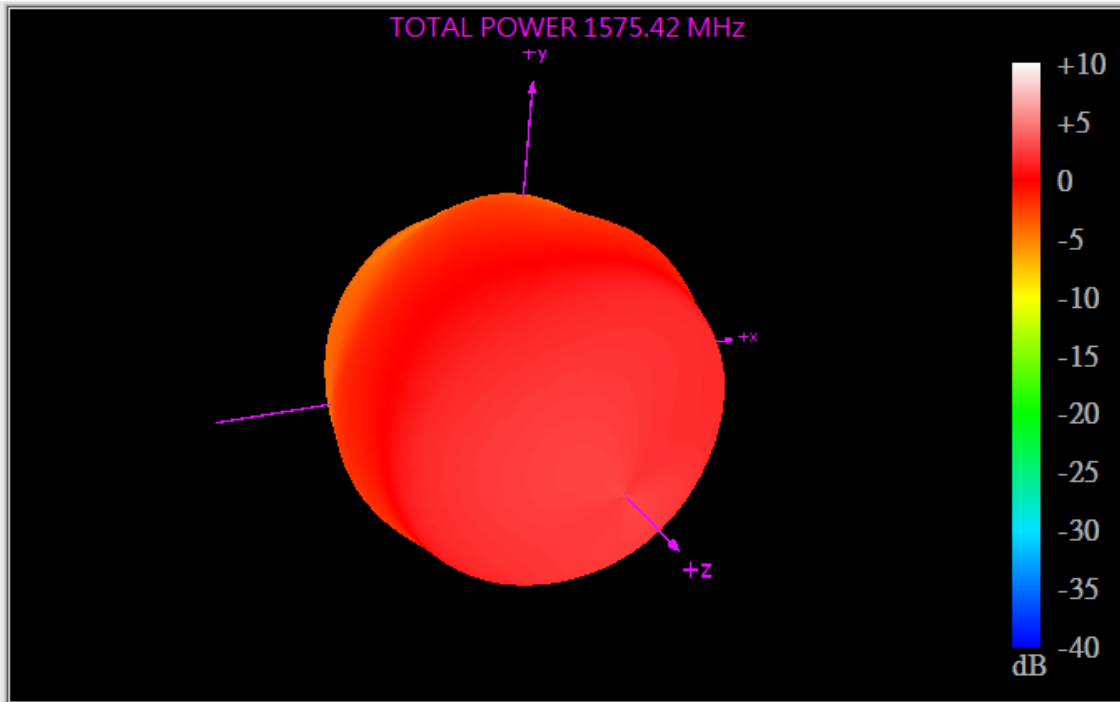

XY Plane                      XZ Plane                      YZ Plane

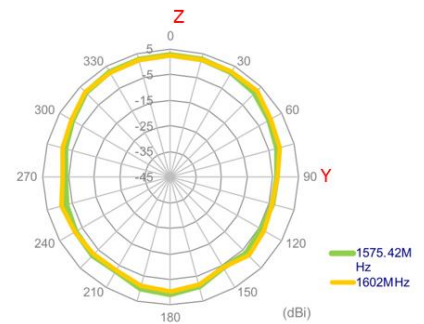
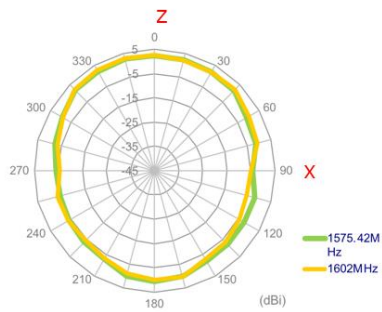
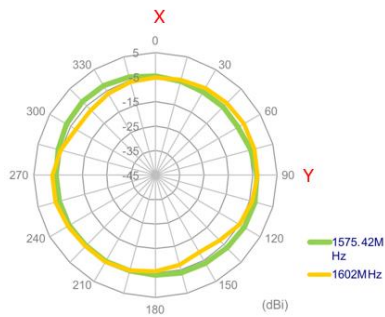



1602MHz

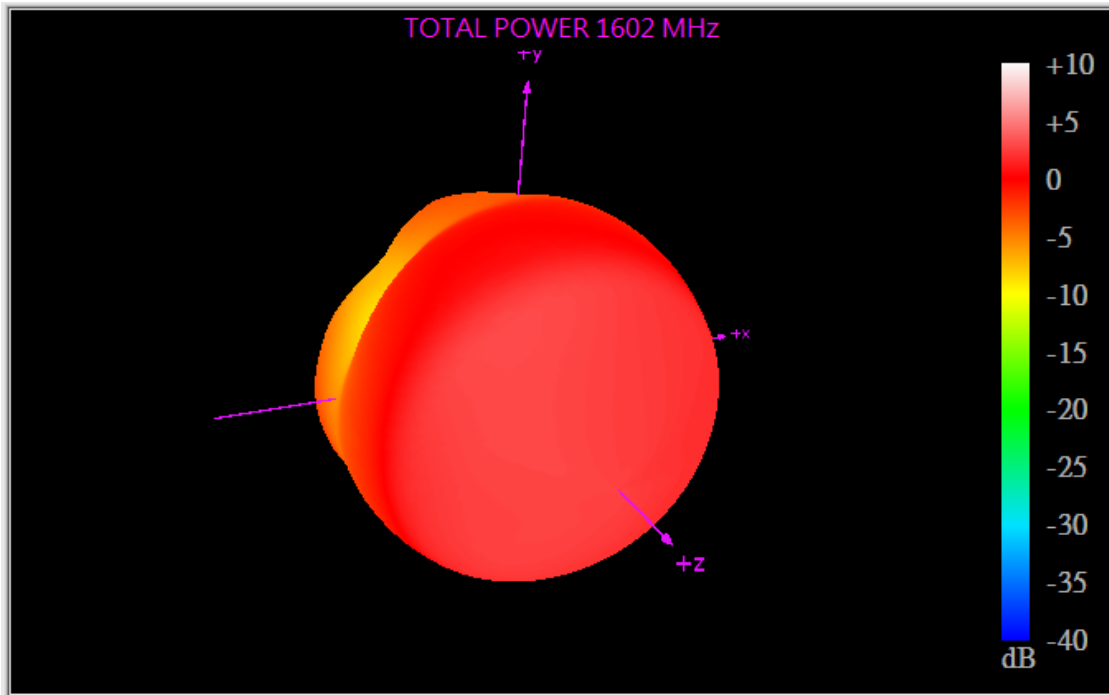

XY Plane

XZ Plane

YZ Plane

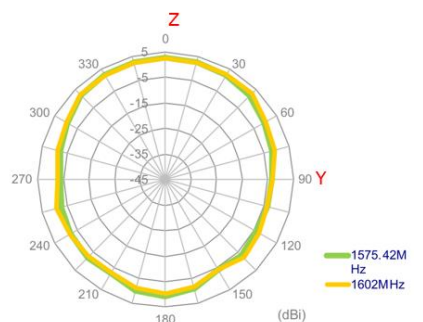
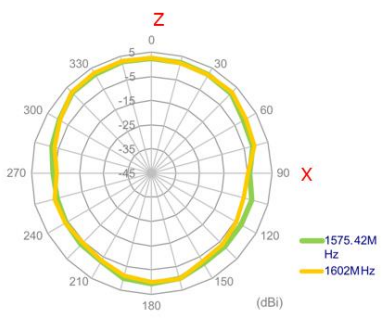
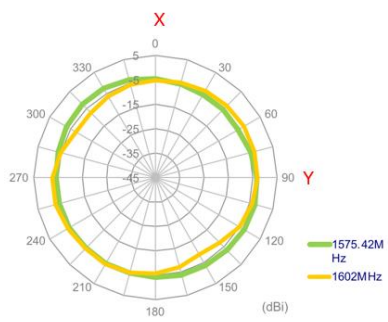

## 5. Mechanical Drawing (Units: mm)

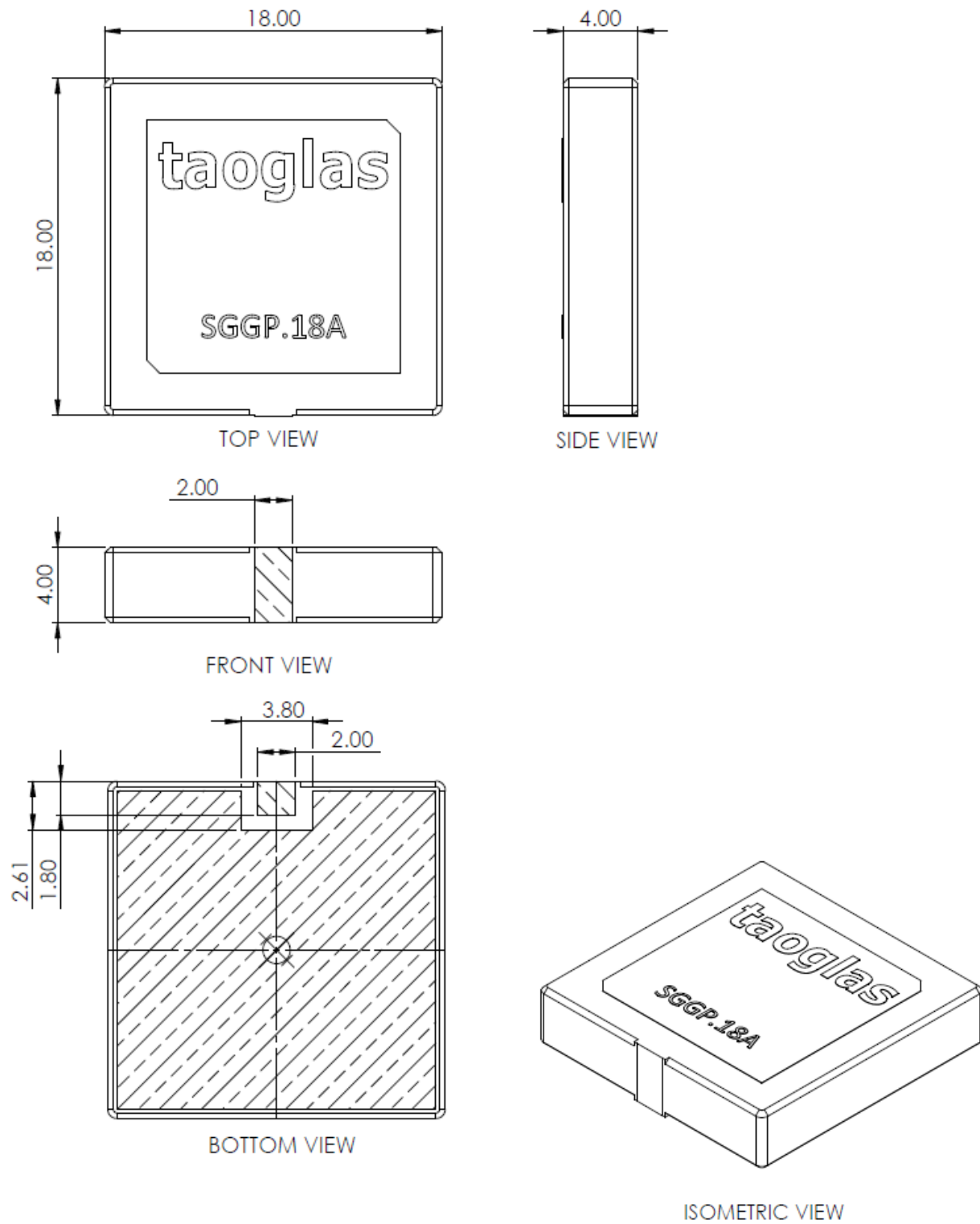

## 6. Antenna Integration Guide

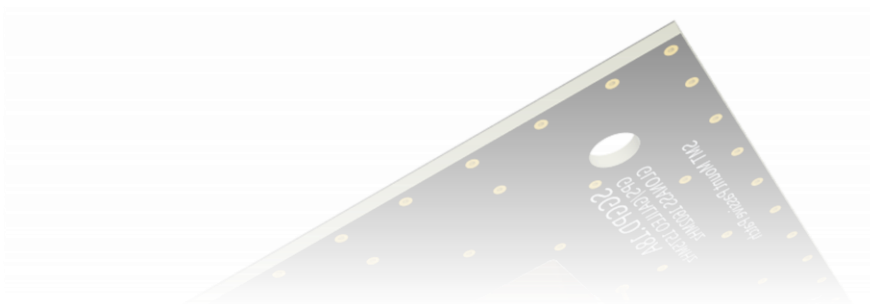
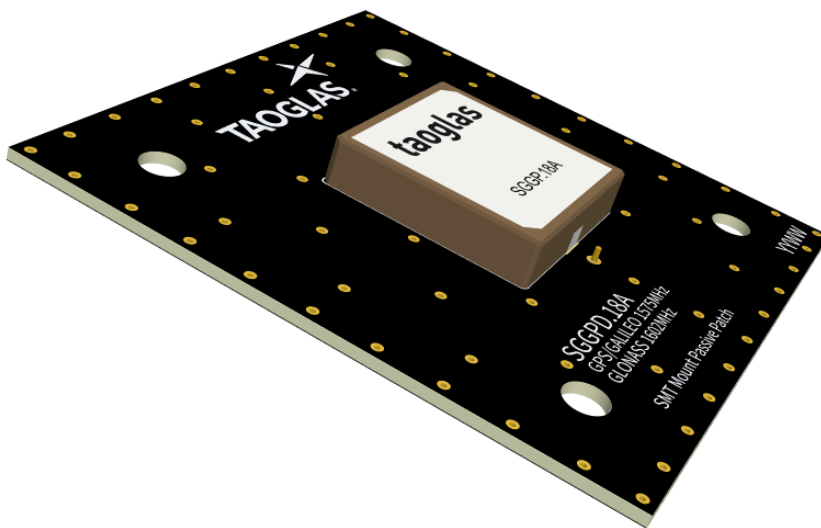

## 6.1 Schematic Symbol and Pin Definition

The circuit symbol for the antenna is shown below. The antenna has 1 pin as an RF Feed and 8 pins used for ground.

Pin	Description
1	RF Feed
2, 3, 4, 5, 6, 7, 8,9	Ground

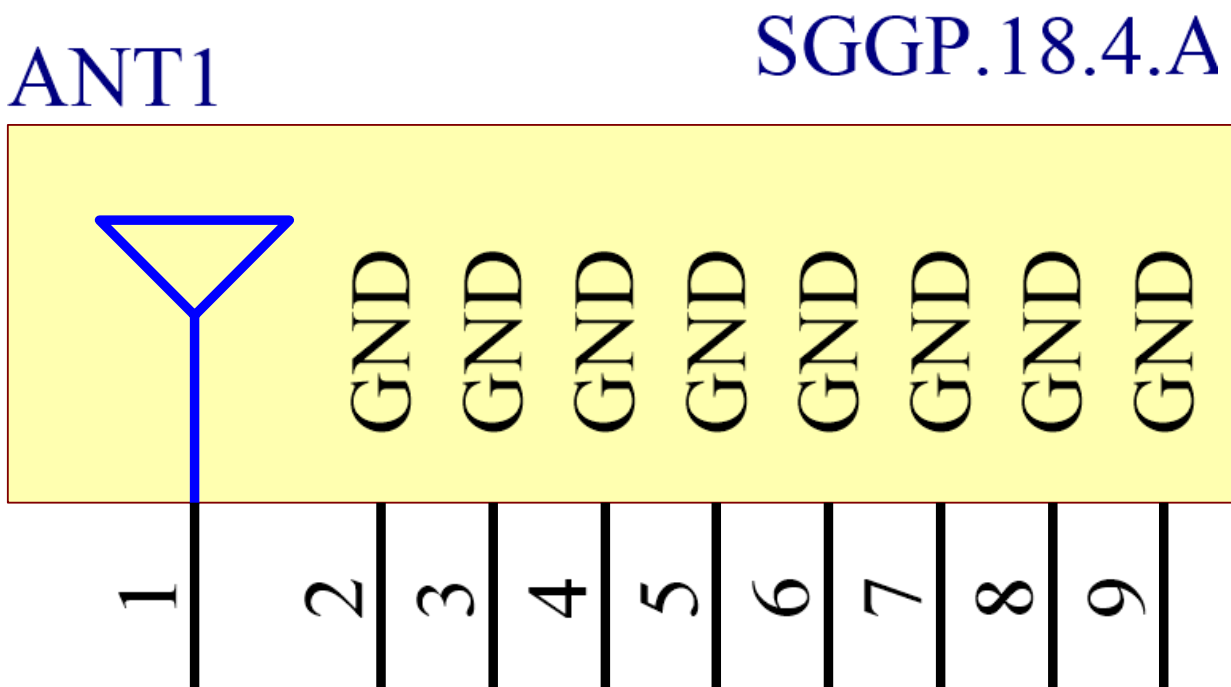

Please note you can download the design files, 3D model, 2D drawings and CST simulation files from the website here:

<https://www.taoglas.com/product/sggp-18-4-a-08-gps-glonass-galileo-smd-18184mm-mount-patch/>

## 6.2 Antenna Integration

Whatever the size of the PCB, the antenna should ideally be placed on the PCB's center, to take advantage of the ground plane.

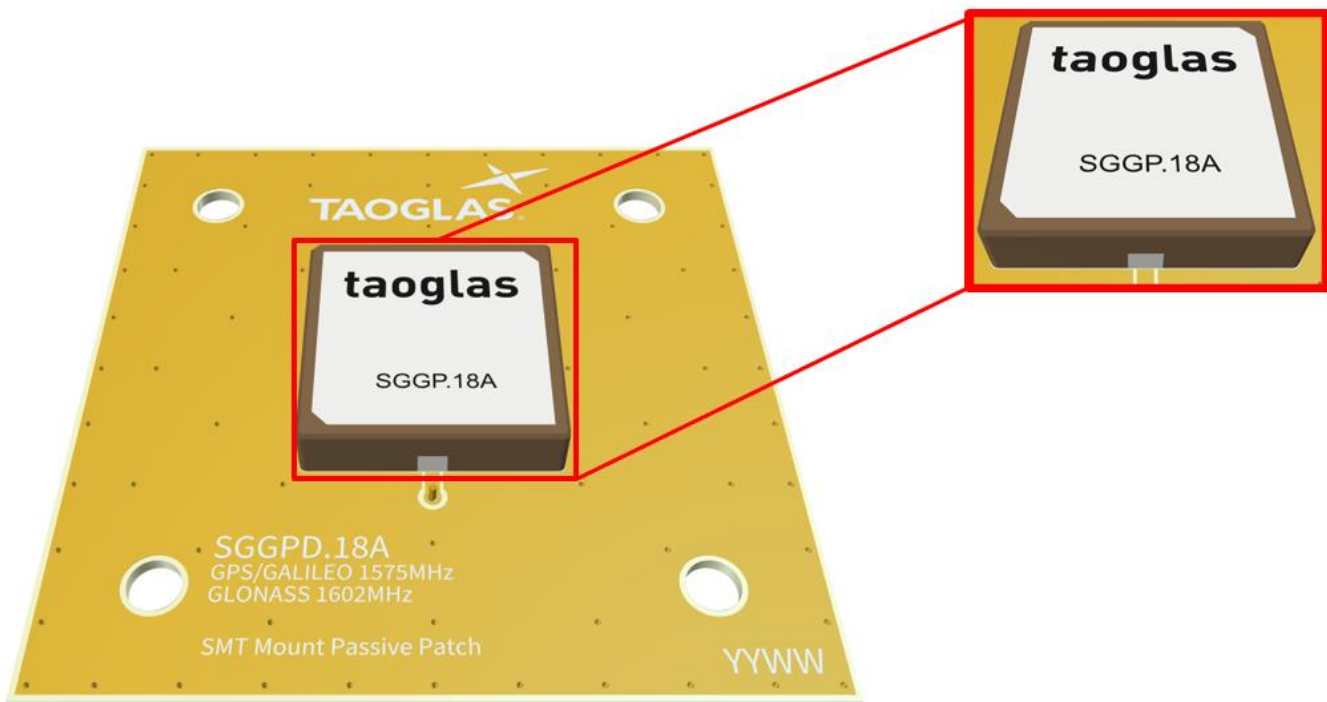
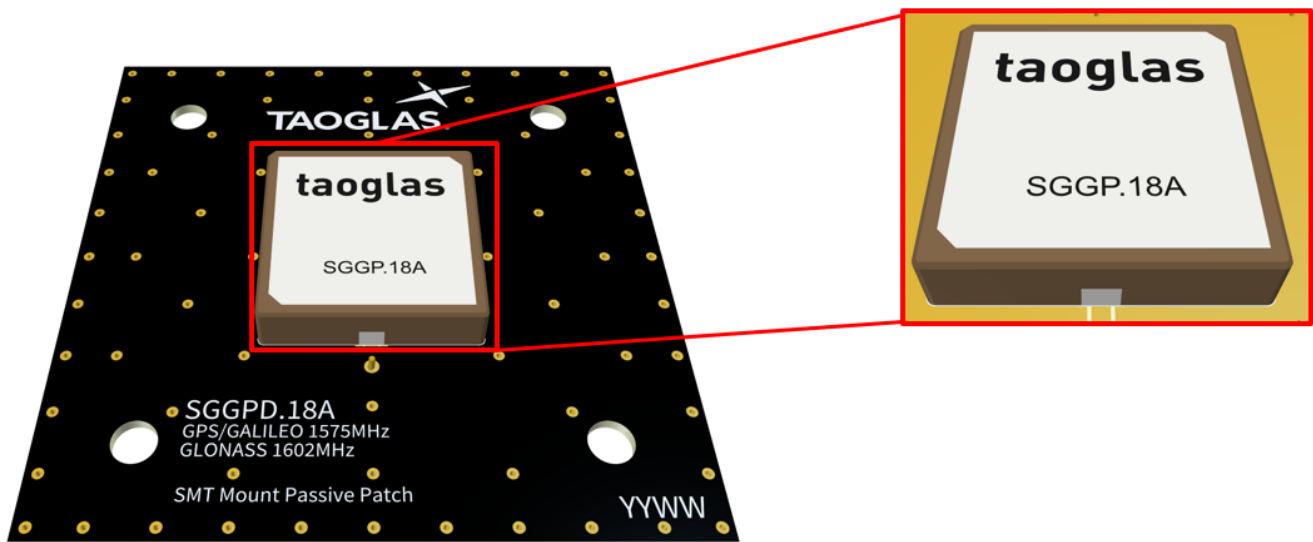

## 6.3 PCB Layout

The footprint and clearance on the PCB must meet the antenna specification. Please note there are no thermal release in the ground plane. It is important to have a solid ground plane under the antenna.

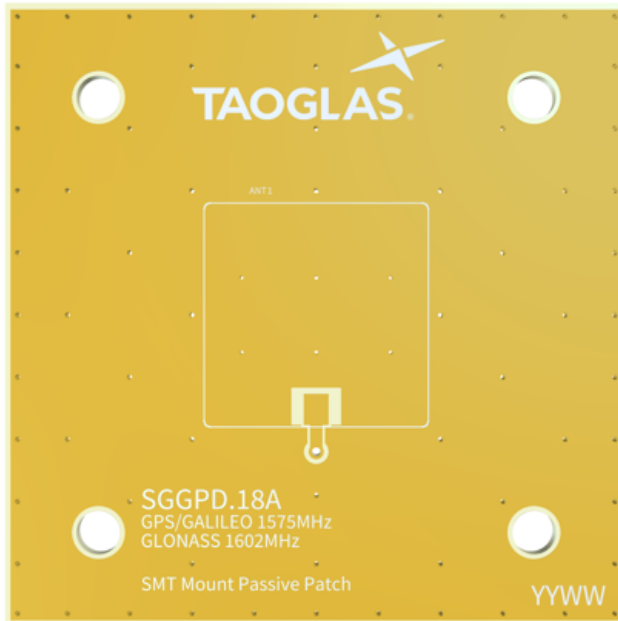

Top side

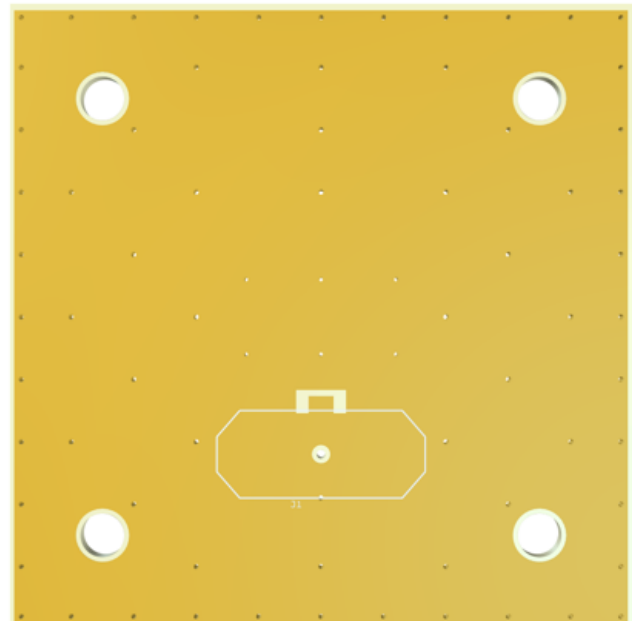

Bottom Side

6.4 Evaluation Board



Topside

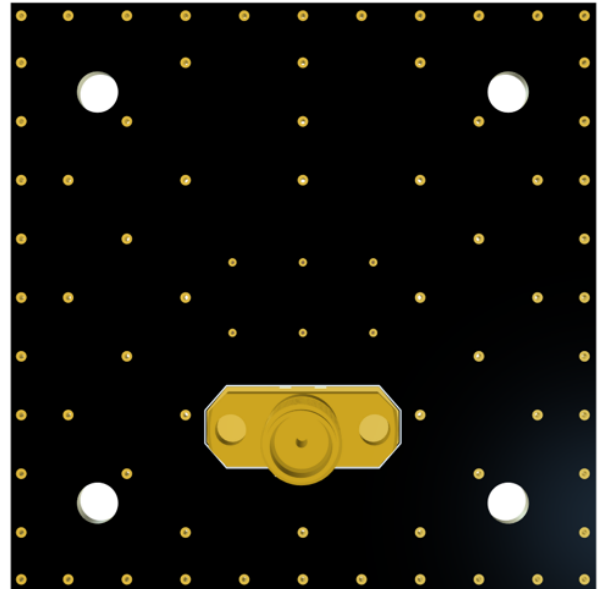

Bottom Side

6.5 Footprint

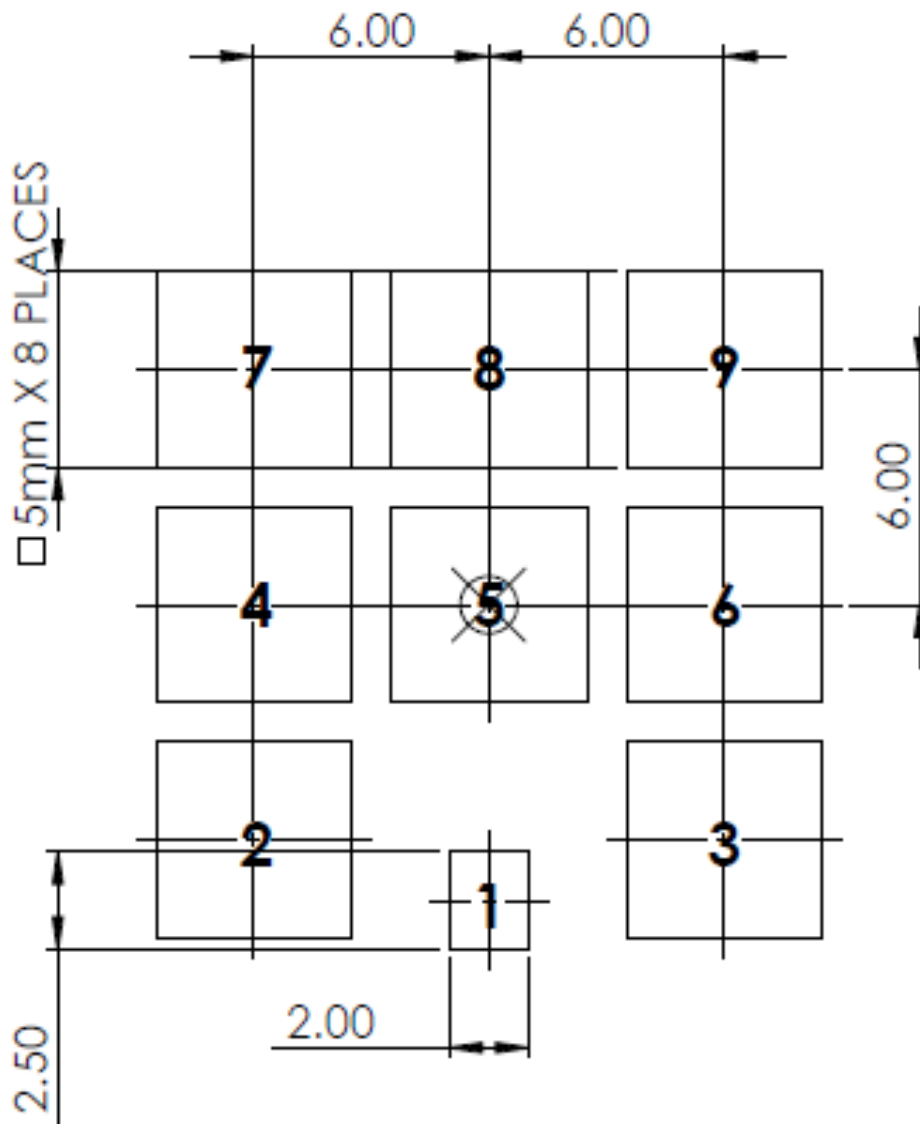

PCB FOOTPRINT

<u>PIN:</u>	<u>DESCRIPTION:</u>
1	RF Feed
2,3,4,5,6,7,8,9	Ground



6.6 PCB Keep Out

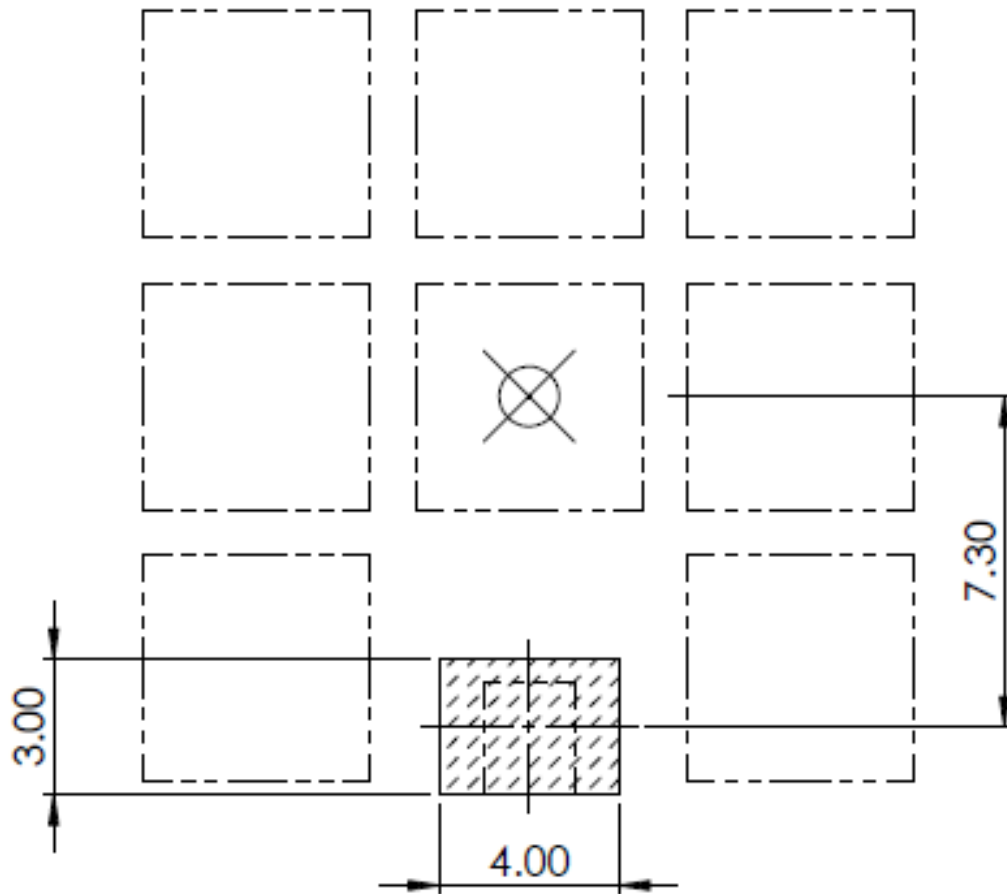

PCB Keep Out Area All Layers

6.7 Solder Paste

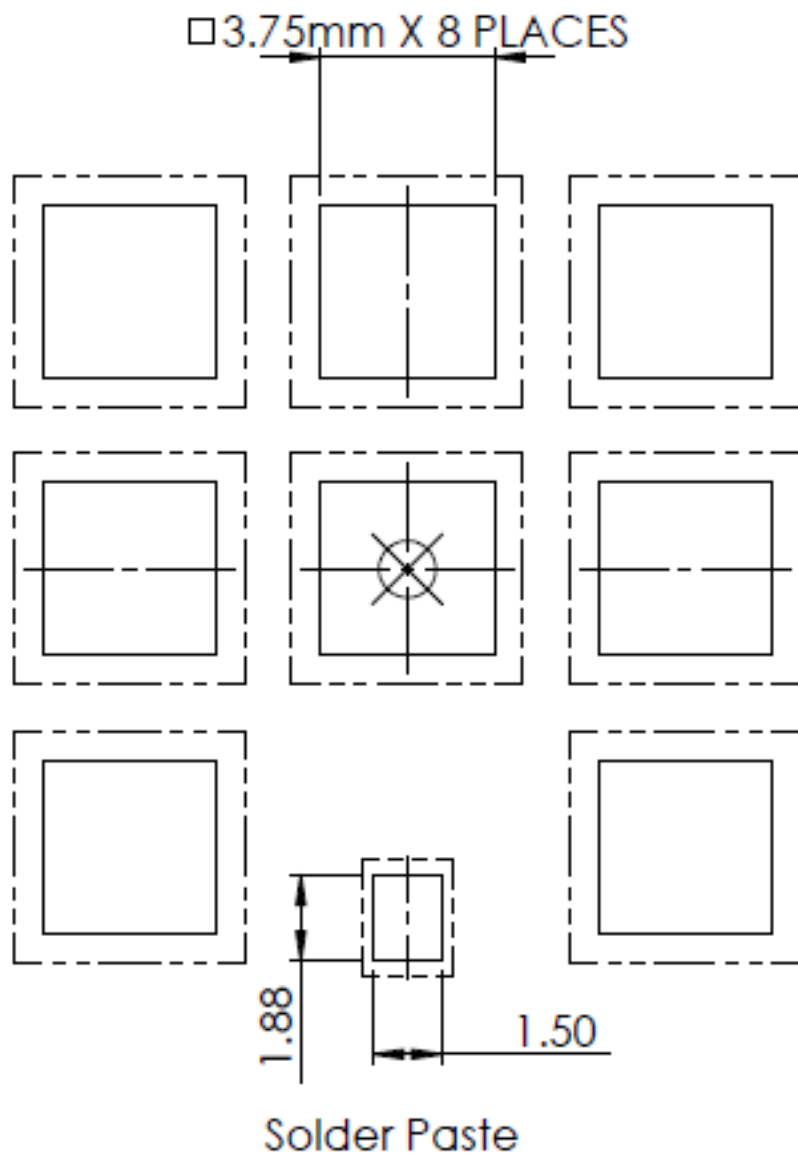

## 7. Packaging

200 pc SGGP.18.4.A.08 per reel  
 Dimensions - Ø330\*33mm  
 Weight - 2.125Kg

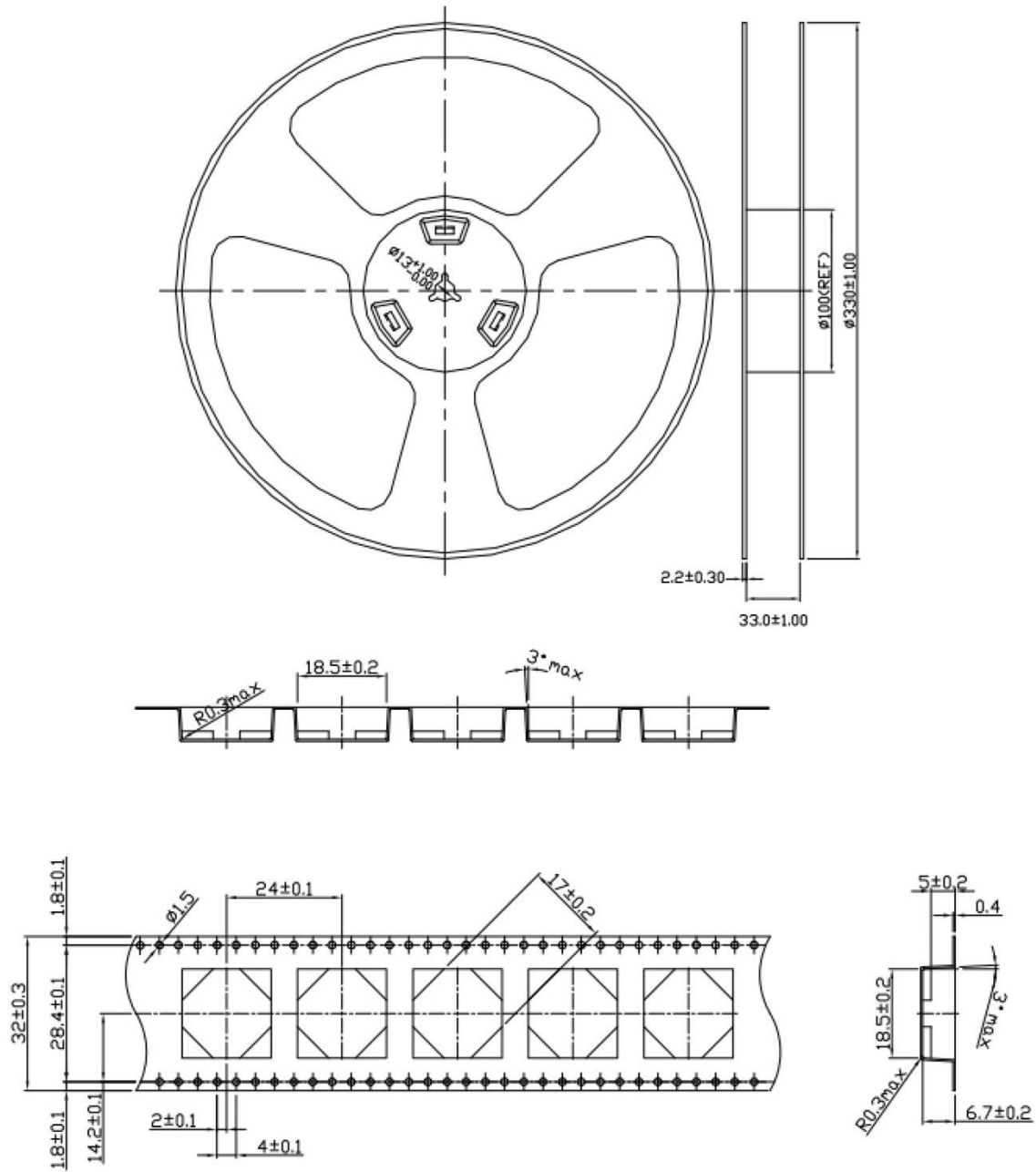

200 pc SGGP.18.4.A.08 per small box  
Dimensions - 350\*340\*67mm  
Weight - 2.125Kg

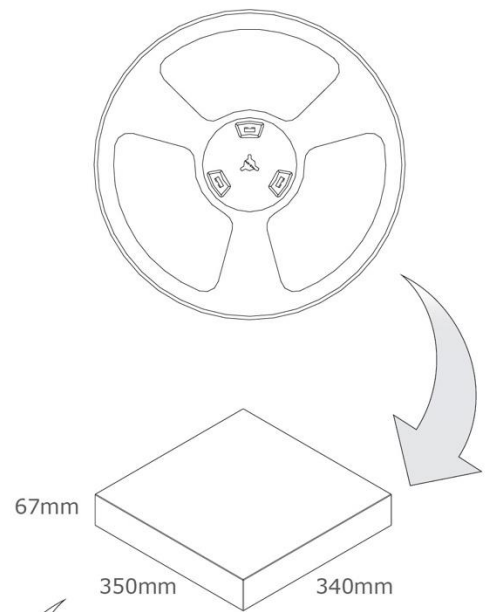

800 pcs SGGP.18.4.A.08 per carton  
Dimensions - 370\*360\*305mm  
Weight - 8.5Kg

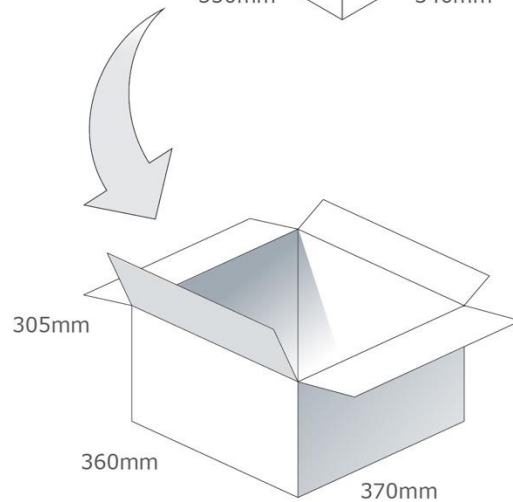

## 8. Soldering Recommendations

### 8.1 Flux Solder

Use rosin-based flux. Don't use highly acidic flux with halide content exceeding 0.2wt%(chlorine conversion value).

- Use Sn solder.

### 8.2 Flux Solder

- Pre-heating should be in such a way that the temperature difference between solder and product surface is limited to 150°C max. Cooling into solvent after soldering also should be in such a way that temperature difference is limited to 100°C max. Unwrought pre-heating may cause cracks on the product, resulting in the deterioration of products quality.

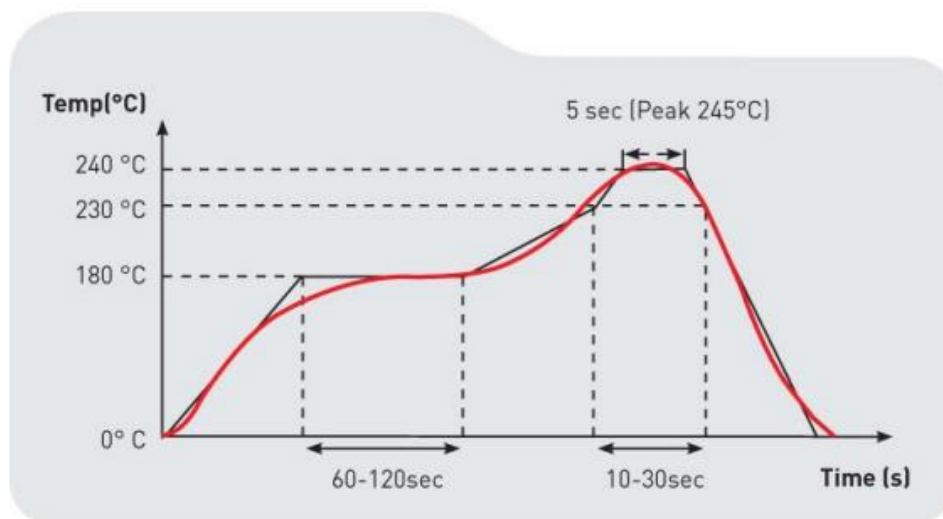

### 8.3 Reworking with Soldering Iron

The following conditions must be strictly followed when using a soldering iron.

Pre -heating	150°C , 1 min
Tip temperature	290°C max
Soldering iron output	30w max
Soldering time	3 Second max

Changelog for the datasheet

**SPE-18-8-067 - SGGP.18.4.A.08**

**Revision: B (Current Version)**

Date:	2021-10-20
Changes:	Full datasheet template update, Addition of MSL to spec table & Integration guide.
Changes Made by:	Gary West

**Previous Revisions**

**Revision: A (Original First Release)**

Date:	2018-07-02
Notes:	First Release
Author:	MC



[www.taoglas.com](http://www.taoglas.com)

