

Aluminum Electrolytic Capacitors SMD (Chip), High Temperature, Low Impedance High Vibration Capability

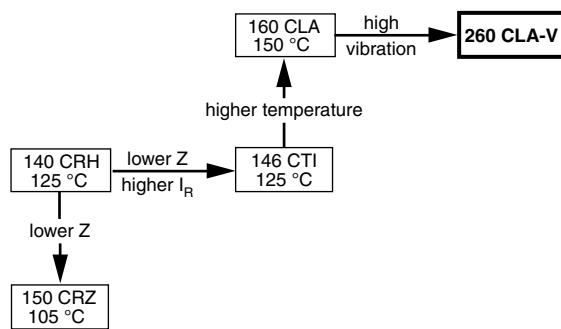

Fig. 1

| QUICK REFERENCE DATA | |
|---|---------------------------------|
| DESCRIPTION | VALUE |
| Nominal case sizes (L x W x H in mm) | 16 x 16 x 16 to 18 x 18 x 21 |
| Rated capacitance range, C_R | 150 μ F to 3300 μ F |
| Tolerance on C_R | ± 20 % |
| Rated voltage range, U_R | 16 V to 80 V |
| Category temperature range | -55 °C to +150 °C |
| Endurance test at 150 °C | 1000 h to 1500 h |
| Useful life at 150 °C | 1500 h to 2000 h |
| Useful life at 40 °C 1.8 x I_R applied | 300 000 h to 400 000 h |
| Shelf life at 0 V, 150 °C | 1000 h |
| Based on sectional specification | IEC 60384-18 / CECC 32300 |
| Climatic category IEC 60068 | 55 / 150 / 56 |

FEATURES

- Useful life: up to 2000 h at 150 °C
- High reliability
- Low ESR
- Polarized aluminum electrolytic capacitors, non-solid electrolyte, self healing
- SMD-version with base plate, lead (Pb)-free reflow solderable
- Charge and discharge proof, no peak current limitation
- High temperature reflow soldering according to JEDEC® J-STD-020
- High temperature proof
- Vibration proof, 6-pin version up to 30 g
- AEC-Q200 qualified
- Material categorization: for definitions of compliance please see www.vishay.com/doc?99912

 AUTOMOTIVE
GRADE

RoHS
COMPLIANT

APPLICATIONS

- SMD technology, for high temperature reflow soldering
- High temperature environment, high peak load
- Automotive, industrial
- Smoothing, filtering, buffering

MARKING

- Rated capacitance (in μ F)
- Rated voltage (in V)
- Date code, in accordance with IEC 60062
- Black mark or “-” sign indicating the cathode (the anode is identified by beveled edges)
- Code indicating group number (A)

PACKAGING

Supplied in blister tape on reel

| SELECTION CHART FOR C_R, U_R, AND RELEVANT NOMINAL CASE SIZES (L x W x H in mm) | | | | | | |
|--|--------------|--------------|--------------|--------------|--------------|--------------|
| C_R (μF) | U_R (V) | | | | | |
| | 16 | 25 | 35 | 50 | 63 | 80 |
| 150 | → | → | → | → | → | 16 x 16 x 16 |
| 220 | → | → | → | → | 16 x 16 x 16 | 18 x 18 x 16 |
| 330 | → | → | → | 16 x 16 x 16 | 18 x 18 x 16 | 18 x 18 x 21 |
| 470 | → | → | 16 x 16 x 16 | 18 x 18 x 16 | 16 x 16 x 21 | - |
| 680 | → | 16 x 16 x 16 | 18 x 18 x 16 | 16 x 16 x 21 | 18 x 18 x 21 | - |
| 1000 | 16 x 16 x 16 | 18 x 18 x 16 | 16 x 16 x 21 | 18 x 18 x 21 | - | - |
| 1500 | 18 x 18 x 16 | 16 x 16 x 21 | 18 x 18 x 21 | - | - | - |
| 2200 | 16 x 16 x 21 | 18 x 18 x 21 | - | - | - | - |
| 2700 | 18 x 18 x 21 | - | - | - | - | - |
| 3300 | 18 x 18 x 21 | - | - | - | - | - |

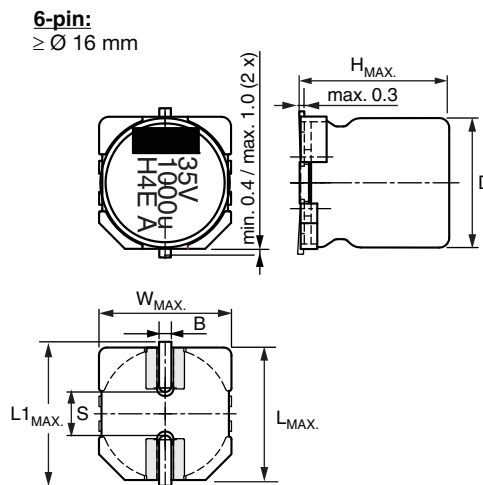

Fig. 1 - Dimensional outline

Table 1

| DIMENSIONS in millimeters AND MASS | | | | | | | | | |
|---|-----------|------------|------------|------------|-----------------|------------|-----|-------------|----------|
| NOMINAL CASE SIZE L x W x H | CASE CODE | $L_{MAX.}$ | $W_{MAX.}$ | $H_{MAX.}$ | $\varnothing D$ | $B_{MAX.}$ | S | $L1_{MAX.}$ | MASS (g) |
| 16 x 16 x 16 | 1616 | 16.6 | 16.6 | 17.5 | 16.0 | 1.3 | 6.5 | 18.6 | ≈ 5.8 |
| 16 x 16 x 21 | 1621 | 16.6 | 16.6 | 22.0 | 16.0 | 1.3 | 6.5 | 18.6 | ≈ 7.1 |
| 18 x 18 x 16 | 1816 | 19.0 | 19.0 | 17.5 | 18.0 | 1.3 | 6.5 | 21.0 | ≈ 8.0 |
| 18 x 18 x 21 | 1821 | 19.0 | 19.0 | 22.0 | 18.0 | 1.3 | 6.5 | 21.0 | ≈ 9.3 |

Table 2

| TAPE AND REEL DIMENSIONS in millimeters, PACKAGING QUANTITIES | | | | | | |
|---|-----------|-------------------------|-----------------|----------------------------------|---------------|-----------------------------|
| NOMINAL CASE SIZE L x W x H | CASE CODE | PITCH P ₁ | TAPE WIDTH W | TAPE THICKNESS T ₂ | REEL DIAMETER | PACKAGING QUANTITY PER REEL |
| 16 x 16 x 16 | 1616 | 28 | 44 | 18.9 | 380 | 150 |
| 16 x 16 x 21 | 1621 | 28 | 44 | 23.4 | 380 | 100 |
| 18 x 18 x 16 | 1816 | 32 | 44 | 18.9 | 380 | 125 |
| 18 x 18 x 21 | 1821 | 32 | 44 | 23.4 | 380 | 100 |

Note

- Detailed tape dimensions see section "PACKAGING"

MOUNTING

The capacitors are designed for automatic placement on to printed-circuit boards.

Optimum dimensions of soldering pads depend amongst others on soldering method, mounting accuracy, print layout and / or adjacent components.

For recommended soldering pad dimensions, refer to Fig. 3 and Table 3.

SOLDERING

Soldering conditions are defined by the curve, temperature versus time, where the temperature is that measured on the component during processing.

For maximum conditions refer to Fig. 4.

Any temperature versus time curve which does not exceed the specified maximum curves may be applied.

As a general principle, temperature and duration shall be the **minimum** necessary required to ensure good soldering connections. However, the specified maximum curves should never be exceeded.

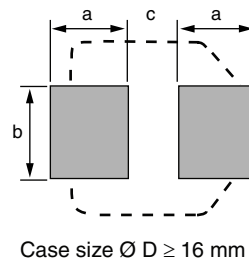

Fig. 2 - Recommended soldering pad dimensions

Table 3

| RECOMMENDED SOLDERING PAD DIMENSIONS in millimeters | | | |
|--|-----|-----|-----|
| CASE CODE | a | b | c |
| 1616 | 7.8 | 9.6 | 4.7 |
| 1621 | 7.8 | 9.6 | 4.7 |
| 1816 | 8.8 | 9.6 | 4.7 |
| 1821 | 8.8 | 9.6 | 4.7 |

**ADVANCED SOLDERING PROFILE FOR LEAD (Pb)-FREE REFLOW PROCESS
ACCORDING TO JEDEC J-STD-020**

Fig. 3 - Maximum temperature load during reflow soldering

Table 4

| REFLOW SOLDERING CONDITIONS for MAL226099xxxE3 | |
|--|---------------------------|
| PROFILE FEATURES | CASE CODE 1616 TO 1821 |
| Maximum time from 25 °C to T_{Peak} | 300 s |
| Maximum ramp-up rate to 150 °C | 3 K/s |
| Maximum time from 150 °C to 200 °C (t_1) | 150 s |
| Maximum time from 190 °C to 200 °C (t_2) | 110 s |
| Ramp up rate from 200 °C to T_{Peak} | 0.5 K/s to 3 K/s |
| Maximum time above $T_{Liquidus}$ (217 °C) (t_3) | 90 s |
| Maximum time above 230 °C (t_4) | 60 s |
| Peak temperature T_{Peak} | 245 °C |
| Maximum time above T_{Peak} minus 5 °C | 30 s |
| Ramp-down rate from $T_{Liquidus}$ | 3 K/s to 6 K/s |

Notes

- Temperature measuring point on top of the case and on terminals.
- Maximum 2 runs with pause of minimum 30 min in between.



| ELECTRICAL DATA | |
|-----------------|---|
| SYMBOL | DESCRIPTION |
| C_R | Rated capacitance at 100 Hz, tolerance $\pm 20\%$ |
| I_R | Rated RMS ripple current at 100 kHz, 150 °C |
| I_{L2} | Maximum leakage current after 2 min at U_R |
| $\tan \delta$ | Maximum dissipation factor at 100 Hz |
| Z | Maximum impedance at 100 kHz |

Note

- Unless otherwise specified, all electrical values in Table 5 apply at $T_{amb} = 20\text{ °C}$, $P = 86\text{ kPa}$ to 106 kPa , $RH = 45\%$ to 75%

ORDERING EXAMPLE

Electrolytic capacitor 260 CLA-V series

330 μF / 50 V; $\pm 20\%$

Nominal case size: 16 mm x 16 mm x 16 mm; taped on reel

Ordering code: MAL226099104E3

Table 5

| ELECTRICAL DATA AND ORDERING INFORMATION | | | | | | | | | |
|--|----------------------------|---|------------------------------------|--|-------------------------|---------------------------------------|--|-----------------------------|-----------------------------|
| U_R (V) | C_R (μF) | NOMINAL CASE SIZE L x W x H (mm) | I_R 150 °C 100 kHz (mA) | I_{L2} 2 min (μA) | $\tan \delta$ 100 Hz | Z 100 kHz 20 °C (Ω) | Z 100 kHz -40 °C (Ω) | LIFE CODE ⁽¹⁾ | ORDERING CODE MAL2260... |
| 16 | 1000 | 16 x 16 x 16 | 850 | 160 | 0.16 | 0.050 | 0.45 | L1 | 99503E3 |
| | 1500 | 18 x 18 x 16 | 900 | 240 | 0.16 | 0.050 | 0.45 | L1 | 99504E3 |
| | 2200 | 16 x 16 x 21 | 1100 | 352 | 0.18 | 0.035 | 0.32 | L3 | 99505E3 |
| | 2700 | 18 x 18 x 21 | 1350 | 432 | 0.18 | 0.035 | 0.32 | L3 | 99506E3 |
| | 3300 | 18 x 18 x 21 | 1400 | 528 | 0.20 | 0.035 | 0.32 | L3 | 99507E3 |
| 25 | 680 | 16 x 16 x 16 | 800 | 170 | 0.14 | 0.050 | 0.45 | L1 | 99603E3 |
| | 1000 | 18 x 18 x 16 | 830 | 250 | 0.14 | 0.050 | 0.45 | L1 | 99604E3 |
| | 1500 | 16 x 16 x 21 | 1050 | 375 | 0.14 | 0.035 | 0.32 | L3 | 99605E3 |
| | 2200 | 18 x 18 x 21 | 1350 | 550 | 0.16 | 0.035 | 0.32 | L3 | 99606E3 |
| 35 | 470 | 16 x 16 x 16 | 800 | 165 | 0.12 | 0.050 | 0.45 | L1 | 99003E3 |
| | 680 | 18 x 18 x 16 | 830 | 238 | 0.12 | 0.050 | 0.45 | L1 | 99004E3 |
| | 1000 | 16 x 16 x 21 | 1000 | 350 | 0.12 | 0.035 | 0.32 | L3 | 99005E3 |
| | 1500 | 18 x 18 x 21 | 1350 | 525 | 0.12 | 0.035 | 0.32 | L3 | 99006E3 |
| 50 | 330 | 16 x 16 x 16 | 700 | 165 | 0.10 | 0.072 | 0.65 | L1 | 99104E3 |
| | 470 | 18 x 18 x 16 | 720 | 235 | 0.10 | 0.070 | 0.63 | L1 | 99105E3 |
| | 680 | 16 x 16 x 21 | 800 | 340 | 0.10 | 0.052 | 0.47 | L3 | 99106E3 |
| | 1000 | 18 x 18 x 21 | 1100 | 500 | 0.10 | 0.049 | 0.44 | L3 | 99107E3 |
| 63 | 220 | 16 x 16 x 16 | 500 | 139 | 0.10 | 0.100 | 0.90 | L1 | 99805E3 |
| | 330 | 18 x 18 x 16 | 520 | 208 | 0.10 | 0.095 | 0.86 | L1 | 99806E3 |
| | 470 | 16 x 16 x 21 | 600 | 296 | 0.10 | 0.075 | 0.68 | L3 | 99807E3 |
| | 680 | 18 x 18 x 21 | 700 | 428 | 0.10 | 0.072 | 0.65 | L3 | 99808E3 |
| 80 | 150 | 16 x 16 x 16 | 430 | 120 | 0.12 | 0.390 | 3.12 | L1 | 99703E3 |
| | 220 | 18 x 18 x 16 | 430 | 176 | 0.12 | 0.390 | 3.12 | L1 | 99704E3 |
| | 330 | 18 x 18 x 21 | 520 | 264 | 0.12 | 0.300 | 2.40 | L2 | 99705E3 |

Note

- ⁽¹⁾ Determines the applicable row in the table “Endurance Test Duration and Useful Life”

Table 6

| EXTENDED VIBRATION SPECIFICATIONS | | |
|-----------------------------------|---|---|
| PARAMETER | PROCEDURE | REQUIREMENTS |
| Vibration improvement | From 10 g to 30 g | No visible damage; no leakage of electrolyte; marking legible $\Delta C/C$: $\pm 5\%$ with respect to initial measurements |
| Vibration frequency range | 10 Hz to 2 kHz | |
| Vibration profile | <ul style="list-style-type: none"> • Constant sinus sweep • 3 directions • 8 h per direction | |

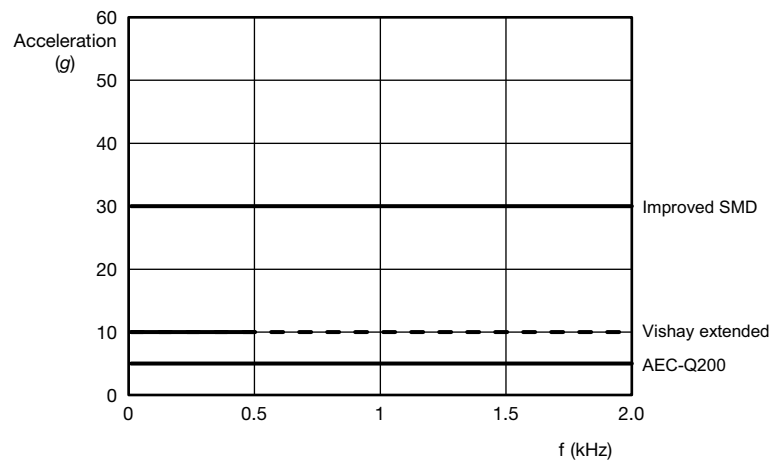

Fig. 4 - Vibration profile

Table 7

| ADDITIONAL ELECTRICAL DATA | | |
|--|---|--|
| PARAMETER | CONDITIONS | VALUE |
| Voltage | | |
| Surge voltage for short periods | IEC 60384-18, subclause 4.14 | $U_s \leq 1.15 \times U_R$ |
| Reverse voltage for short periods | IEC 60384-18, subclause 4.16; $T_A \leq 150\text{ °C}$ | $U_{rev} \leq 1\text{ V}$ |
| Current | | |
| Leakage current | After 2 min at U_R | $I_{L2} \leq 0.01 \times C_R \times U_R$ |
| Inductance | | |
| Equivalent series inductance (ESL) | $\varnothing D \geq 16\text{ mm}$ | Typ. 11 nH |
| Resistance | | |
| Equivalent series resistance (ESR) at 100 Hz | Calculated from $\tan \delta_{max}$ and C_R (see Table 5) | $ESR = \tan \delta / 2\pi f C_R$ |

CAPACITANCE (C)

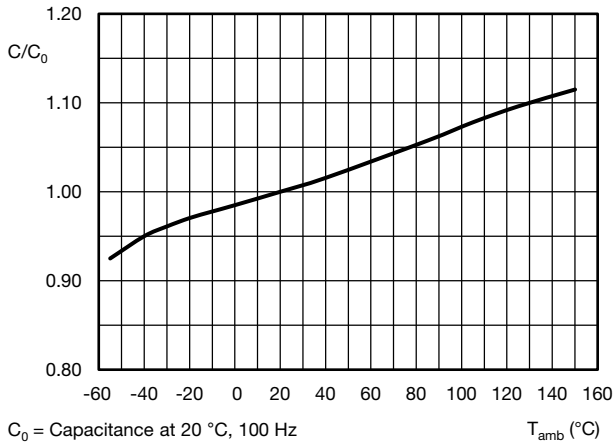

Fig. 5 - Typical multiplier of capacitance as a function of ambient temperature

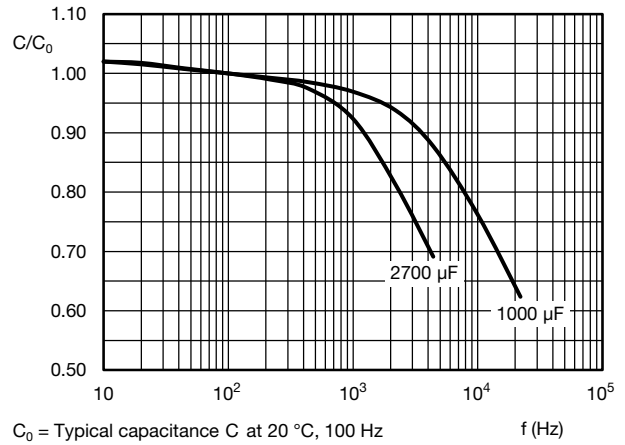

Fig. 6 - Typical multiplier of capacitance as a function of frequency

DISSIPATION FACTOR (tan δ)

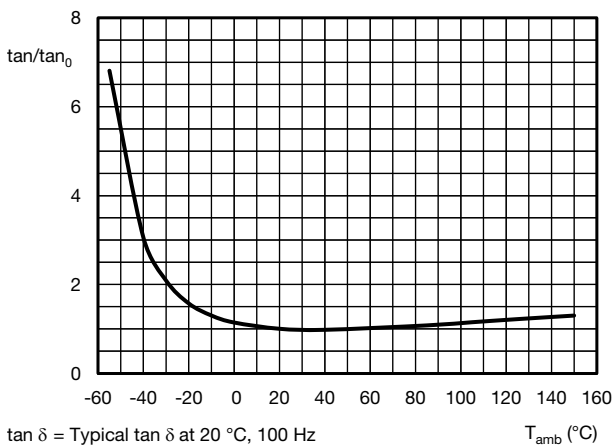

Fig. 7 - Typical multiplier of dissipation factor ($\tan \delta$) as a function of ambient temperature

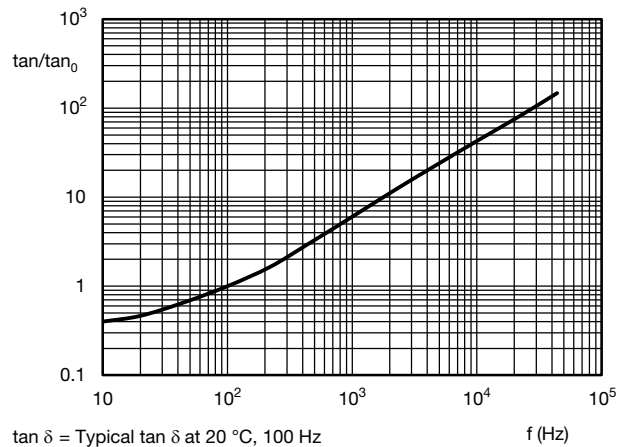

Fig. 8 - Typical multiplier of dissipation factor ($\tan \delta$) as a function of frequency

EQUIVALENT SERIES RESISTANCE (ESR)

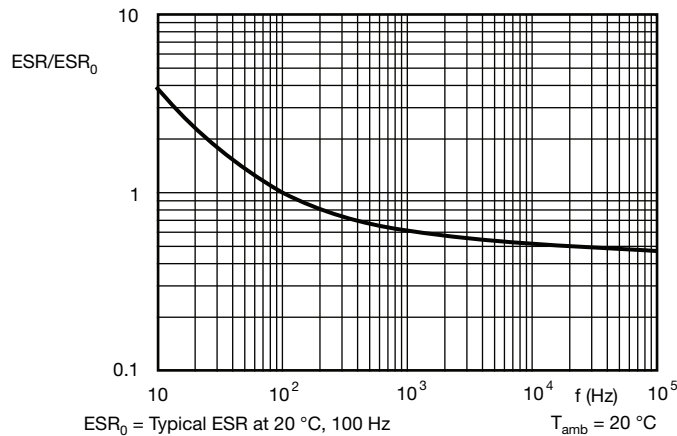

Fig. 9 - Typical multiplier of ESR as a function of frequency

IMPEDANCE (Z)

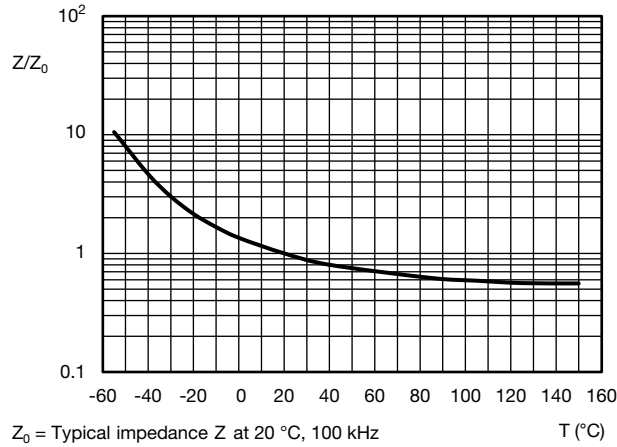

Fig. 10 - Typical multiplier of impedance as a function of temperature

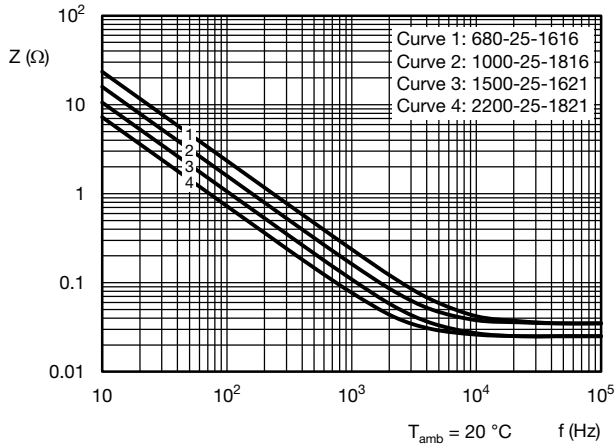

Fig. 11 - Typical impedance as a function of frequency

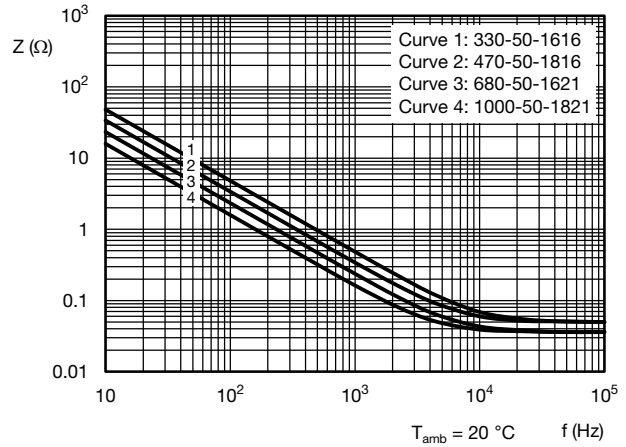

Fig. 12 - Typical impedance as a function of frequency

RIPPLE CURRENT AND USEFUL LIFE

Table 8

| ENDURANCE TEST DURATION AND USEFUL LIFE | | | |
|---|-------------------------|---------------------------|---|
| LIFE CODE | ENDURANCE AT 150 °C (h) | USEFUL LIFE AT 150 °C (h) | USEFUL LIFE AT 40 °C 1.8 x I _R APPLIED (h) |
| L1 | 1000 | 1500 | 350 000 |
| L2 | 1500 | 1500 | 350 000 |
| L3 | 1500 | 2000 | 400 000 |

Note

- Multiplier of useful life code: MBC245

MBC245

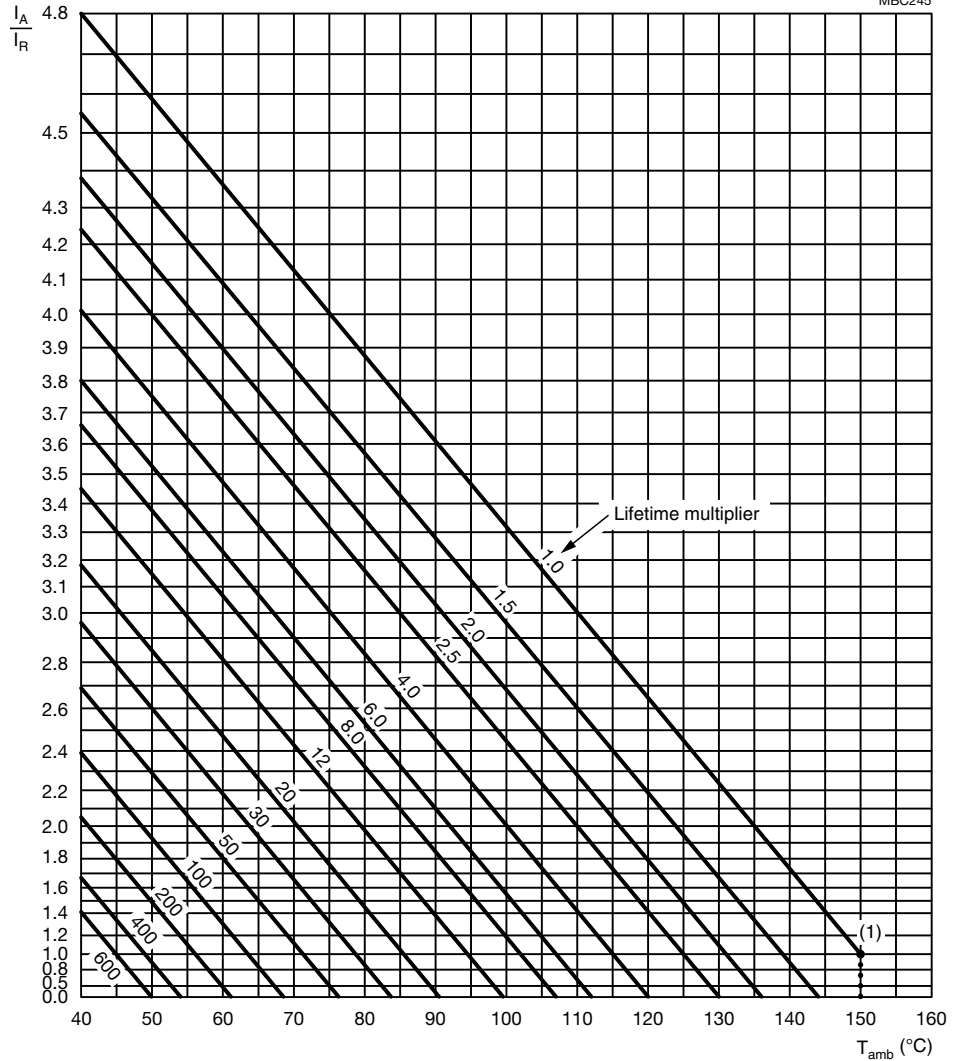

I_A = Actual ripple current at 100 kHz
 I_R = Rated ripple current at 100 kHz, 150 °C
 (1) Useful life at 150 °C and I_R applied; see Table 7

Fig. 13 - Multiplier of useful life as a function of ambient temperature and ripple current load

Table 9

| MULTIPLIER OF RIPPLE CURRENT (I_R) AS A FUNCTION OF FREQUENCY | | | | | | | |
|---|------|------|------|------|--------|--------|---------|
| FREQUENCY (Hz) | | | | | | | |
| 50 | 100 | 300 | 1000 | 3000 | 10 000 | 30 000 | 100 000 |
| I_R MULTIPLIER | | | | | | | |
| 0.40 | 0.60 | 0.75 | 0.80 | 0.90 | 0.95 | 0.97 | 1.00 |



Table 10

| TEST PROCEDURES AND REQUIREMENTS | | | |
|--|---|--|--|
| TEST | | PROCEDURE (quick reference) | REQUIREMENTS |
| NAME OF TEST | REFERENCE | | |
| Mounting | IEC 60384-18, subclause 4.3 | Shall be performed prior to tests mentioned below; reflow soldering; for maximum temperature load refer to chapter "Mounting" | $\Delta C/C: \pm 5 \%$ $\tan \delta \leq \text{spec. limit}$ $I_{L2} \leq \text{spec. limit}$ |
| Endurance | IEC 60384-18 / CECC 32300, subclause 4.15 | $T_{amb} = 150 \text{ }^\circ\text{C}$; U_R applied; for test duration see Table 7 | $\Delta C/C: \pm 20 \%$ $\tan \delta \leq 2 \times \text{spec. limit}$ $I_{L2} \leq \text{spec. limit}$ |
| Useful life | CECC 30301, subclause 1.8.1 | $T_{amb} = 150 \text{ }^\circ\text{C}$; U_R and I_R applied; for test duration see Table 7 | $\Delta C/C: \pm 30 \%$ $\tan \delta \leq 3 \times \text{spec. limit}$ $I_{L2} \leq \text{spec. limit}$ no short or open circuit total failure percentage: $\leq 1 \%$ |
| Shelf life (storage at high temperature) | IEC 60384-18 / CECC 32300, subclause 4.17 | $T_{amb} = 150 \text{ }^\circ\text{C}$; no voltage applied; 1000 h After test: U_R to be applied for 30 min, 24 h to 48 h before measurement | For requirements see "Endurance test" above |
| Reverse voltage | IEC 60384-18 / CECC 32300, subclause 4.16 | $T_{amb} = 150 \text{ }^\circ\text{C}$: 125 h at $U = -0.5 \text{ V}$, followed by 125 h at U_R | $\Delta C/C: \pm 15 \%$ $\tan \delta \leq 1.5 \times \text{spec. limit}$ $I_{L2} \leq \text{spec. limit}$ |

Statements about product lifetime are based on calculations and internal testing. They should only be interpreted as estimations. Also due to external factors, the lifetime in the field application may deviate from the calculated lifetime. In general, nothing stated herein shall be construed as a guarantee of durability.



Disclaimer

ALL PRODUCT, PRODUCT SPECIFICATIONS AND DATA ARE SUBJECT TO CHANGE WITHOUT NOTICE TO IMPROVE RELIABILITY, FUNCTION OR DESIGN OR OTHERWISE.

Vishay Intertechnology, Inc., its affiliates, agents, and employees, and all persons acting on its or their behalf (collectively, "Vishay"), disclaim any and all liability for any errors, inaccuracies or incompleteness contained in any datasheet or in any other disclosure relating to any product.

Vishay makes no warranty, representation or guarantee regarding the suitability of the products for any particular purpose or the continuing production of any product. To the maximum extent permitted by applicable law, Vishay disclaims (i) any and all liability arising out of the application or use of any product, (ii) any and all liability, including without limitation special, consequential or incidental damages, and (iii) any and all implied warranties, including warranties of fitness for particular purpose, non-infringement and merchantability.

Statements regarding the suitability of products for certain types of applications are based on Vishay's knowledge of typical requirements that are often placed on Vishay products in generic applications. Such statements are not binding statements about the suitability of products for a particular application. It is the customer's responsibility to validate that a particular product with the properties described in the product specification is suitable for use in a particular application. Parameters provided in datasheets and / or specifications may vary in different applications and performance may vary over time. All operating parameters, including typical parameters, must be validated for each customer application by the customer's technical experts. Product specifications do not expand or otherwise modify Vishay's terms and conditions of purchase, including but not limited to the warranty expressed therein.

Hyperlinks included in this datasheet may direct users to third-party websites. These links are provided as a convenience and for informational purposes only. Inclusion of these hyperlinks does not constitute an endorsement or an approval by Vishay of any of the products, services or opinions of the corporation, organization or individual associated with the third-party website. Vishay disclaims any and all liability and bears no responsibility for the accuracy, legality or content of the third-party website or for that of subsequent links.

Except as expressly indicated in writing, Vishay products are not designed for use in medical, life-saving, or life-sustaining applications or for any other application in which the failure of the Vishay product could result in personal injury or death. Customers using or selling Vishay products not expressly indicated for use in such applications do so at their own risk. Please contact authorized Vishay personnel to obtain written terms and conditions regarding products designed for such applications.

No license, express or implied, by estoppel or otherwise, to any intellectual property rights is granted by this document or by any conduct of Vishay. Product names and markings noted herein may be trademarks of their respective owners.