

## Bottom Port PDM Low-Power Multi-Mode Microphone With High AOP Mode

### GENERAL DESCRIPTION

The T3902 is a low-power, low-noise digital MEMS microphone in a small package. The T3902 consists of a MEMS microphone element and an impedance converter amplifier followed by a fourth-order  $\Sigma$ - $\Delta$  modulator. The pulse density modulated (PDM) interface allows two microphones to be time multiplexed on a data line using a single clock.

The T3902 has multiple modes of operation: High Performance, Low Power (AlwaysOn), Standard and Sleep. The T3902 has low power and high SNR in all operational modes. It has 126 dB SPL AOP in High Performance mode, and 120 dB SPL AOP in Standard and Low-Power modes.

The T3902 is available in a small 3.5 × 2.65 × 0.98 mm surface-mount package. It is reflow solder compatible with no sensitivity degradation.

### APPLICATIONS

- Smartphones
- Microphone Arrays
- Tablets
- Cameras
- Bluetooth Headsets
- Notebook PCs
- Security and Surveillance

### FEATURES

SPEC	LOW-POWER MODE	STANDARD MODE	HIGH PERFORMANCE MODE
<b>Sensitivity</b>	-26 dB FS $\pm$ 1 dB	-26 dB FS $\pm$ 1 dB	-32 dB FS $\pm$ 1 dB
<b>SNR</b>	63 dBA	64.5 dBA	64 dBA
<b>Current</b>	185 $\mu$ A	430 $\mu$ A	650 $\mu$ A
<b>AOP</b>	120 dB SPL	120 dB SPL	126 dB SPL
<b>Clock</b>	400 – 800 kHz	1.0 – 3.3 MHz	4.1 – 4.8 MHz

- 3.5 × 2.65 × 0.98 mm surface-mount package
- Low power: 185  $\mu$ A in Low-Power Mode
- Extended frequency response from 36 Hz to >20 kHz
- Sleep Mode: 12  $\mu$ A
- High power supply rejection (PSR): -97 dB FS
- Fourth-order  $\Sigma$ - $\Delta$  modulator
- Digital pulse density modulation (PDM) output
- Compatible with Sn/Pb and Pb-free solder processes
- RoHS/WEEE compliant

### FUNCTIONAL BLOCK DIAGRAM

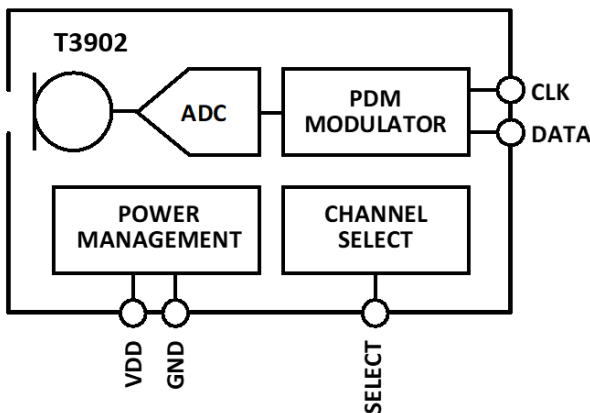

### ORDERING INFORMATION

PART	TEMP RANGE	PACKAGING
MMICT3902-00-012	-40°C to +85°C	13" Tape and Reel
EV_T3902-FX	—	

**TABLE OF CONTENTS**

General Description ..... 1

Applications ..... 1

Features ..... 1

Functional Block Diagram ..... 1

Ordering Information..... 1

Table of Contents ..... 2

Specifications ..... 4

    Table 1. Acoustical/Electrical Characteristics – General ..... 4

    Table 2. Acoustical/Electrical Characteristics – High-Performance Mode ..... 4

    Table 3. Acoustical/Electrical Characteristics – Standard Mode..... 5

    Table 4. Acoustical/Electrical Characteristics – Low-Power Mode ..... 5

    Table 5. Digital Input/Output Characteristics ..... 6

    Table 6. PDM Digital Input/Output ..... 6

    Timing Diagram ..... 7

Absolute Maximum Ratings ..... 8

    Table 7. Absolute Maximum Ratings ..... 8

    ESD Caution ..... 8

    Soldering Profile..... 9

    Table 8. Recommended Soldering Profile\* ..... 9

Pin Configurations And Function Descriptions ..... 10

    Table 9. Pin Function Descriptions..... 10

Typical Performance Characteristics..... 11

Theory Of Operation ..... 12

    PDM Data Format ..... 12

    Table 10. T3902 Channel Setting ..... 12

    PDM Microphone Sensitivity ..... 12

Applications Information ..... 14

    Low Power Mode..... 14

    Dynamic Range Considerations ..... 14

    Connecting PDM Microphones..... 14

    Sleep Mode ..... 16

    Start-Up Time..... 16

Supporting Documents ..... 17

    Application Notes ..... 17

PCB Design And Land Pattern Layout ..... 18

    PCB Material And Thickness ..... 18

Handling Instructions ..... 19

    Pick And Place Equipment ..... 19

---

Reflow Solder.....	19
Board Wash .....	19
Outline Dimensions.....	20
Ordering Guide .....	20
Revision History .....	21
Compliance Declaration Disclaimer .....	22

## SPECIFICATIONS

**TABLE 1. ACOUSTICAL/ELECTRICAL CHARACTERISTICS – GENERAL**

T<sub>A</sub> = 25°C, V<sub>DD</sub> = 1.8 to 3.3 V, SCK = 2.4 MHz, 50× decimation, C<sub>LOAD</sub> = 30 pF unless otherwise noted. Typical specifications are not guaranteed.

PARAMETER	CONDITIONS	MIN	TYP	MAX	UNITS	NOTES
<b>PERFORMANCE</b>						
Directionality		Omni				
Output Polarity	Input acoustic pressure vs. output data	Non-Inverted				
Supply Voltage (V <sub>DD</sub> )		1.65		3.63	V	
Sleep Mode Current (I <sub>S</sub> )	SCK < 200 kHz		12	20	μA	

**TABLE 2. ACOUSTICAL/ELECTRICAL CHARACTERISTICS – HIGH-PERFORMANCE MODE**

T<sub>A</sub> = 25°C, V<sub>DD</sub> = 1.8 to 3.3 V, SCK = 4.8 MHz, 50× decimation, C<sub>LOAD</sub> = 30 pF unless otherwise noted. Typical specifications are not guaranteed.

PARAMETER	CONDITIONS	MIN	TYP	MAX	UNITS	NOTES
Sensitivity	1 kHz, 94 dB SPL	-33	-32	-31	dB FS	1, 2
Signal-to-Noise Ratio (SNR)	20 kHz bandwidth, A-weighted		64		dBA	
Equivalent Input Noise (EIN)	20 kHz bandwidth, A-weighted		30		dBA SPL	
Dynamic Range	Derived from EIN and AOP		96		dB	
Low frequency -3 dB point			36		Hz	3
Total Harmonic Distortion (THD)	105 dB SPL		0.2	1	%	
Power Supply Rejection (PSR)	217 Hz, 100 mV p-p square wave superimposed on V <sub>DD</sub> = 1.8 V, A-weighted		-97		dB FS	
Power Supply Rejection—Swept Sine	1 kHz sine wave		-100		dB FS	
Acoustic Overload Point	10% THD		126		dB SPL	
Full-Scale Acoustic Level	0 dB FS output		126		dB SPL	
Supply Current (I <sub>S</sub> )	V <sub>DD</sub> = 1.8 V, no load		650	750	μA	

**Note 1:** Sensitivity is relative to the RMS level of a sine wave with positive amplitude equal to 100% 1s density and negative amplitude equal to 0% 1s density.

**Note 2:** The sensitivity shall not deviate more than 1.0 dB from its initial value after reliability tests.

**Note 3:** See Figure 4.

**TABLE 3. ACOUSTICAL/ELECTRICAL CHARACTERISTICS – STANDARD MODE**

T<sub>A</sub> = 25°C, VDD = 1.8 to 3.3 V, SCK = 2.4 MHz, 50× decimation, C<sub>LOAD</sub> = 30 pF unless otherwise noted. Typical specifications are not guaranteed.

PARAMETER	CONDITIONS	MIN	TYP	MAX	UNITS	NOTES
Sensitivity	1 kHz, 94 dB SPL	-27	-26	-25	dB FS	1, 2
Signal-to-Noise Ratio (SNR)	20 kHz bandwidth, A-weighted		64.5		dBA	
Equivalent Input Noise (EIN)	20 kHz bandwidth, A-weighted		29.5		dBA SPL	
Dynamic Range	Derived from EIN and AOP		90.5		dB	
Low frequency -3 dB point			36		Hz	3
Total Harmonic Distortion (THD)	105 dB SPL		0.2	1	%	
Power Supply Rejection (PSR)	217 Hz, 100 mV p-p square wave superimposed on VDD = 1.8 V, A-weighted		-97		dB FS	
Power Supply Rejection—Swept Sine	1 kHz sine wave		-104		dB FS	
Acoustic Overload Point	10% THD		120		dB SPL	
Full-Scale Acoustic Level	0 dB FS output		120		dB SPL	
Supply Current (I <sub>S</sub> )	V <sub>DD</sub> = 1.8 V, no load		430	500	μA	

**Note 1:** Sensitivity is relative to the RMS level of a sine wave with positive amplitude equal to 100% 1s density and negative amplitude equal to 0% 1s density.

**Note 2:** The sensitivity shall not deviate more than 1.0 dB from its initial value after reliability tests.

**Note 3:** See See Figure 4.

**TABLE 4. ACOUSTICAL/ELECTRICAL CHARACTERISTICS – LOW-POWER MODE**

T<sub>A</sub> = 25°C, VDD = 1.8 to 3.3 V, SCK = 768 kHz, 50× decimation, C<sub>LOAD</sub> = 30 pF unless otherwise noted. Typical specifications are not guaranteed.

PARAMETER	CONDITIONS	MIN	TYP	MAX	UNITS	NOTES
Sensitivity	1 kHz, 94 dB SPL	-27	-26	-25	dB FS	1, 2
Signal-to-Noise Ratio (SNR)	8 kHz bandwidth, A-weighted		63		dBA	
Equivalent Input Noise (EIN)	8 kHz bandwidth, A-weighted		31		dBA SPL	
Dynamic Range	Derived from EIN and AOP		89		dB	
Low frequency -3 dB point			36		Hz	3
Total Harmonic Distortion (THD)	105 dB SPL		0.2	1	%	
Power Supply Rejection (PSR)	217 Hz, 100 mV p-p square wave superimposed on VDD = 1.8 V, A-weighted		-97		dB FS	
Power Supply Rejection—Swept Sine	1 kHz sine wave		-98		dB FS	
Acoustic Overload Point	10% THD		120		dB SPL	
Full-Scale Acoustic Level	0 dB FS output		120		dB SPL	
Supply Current (I <sub>S</sub> )	V <sub>DD</sub> = 1.8 V, no load		185	225	μA	

**Note 1:** Sensitivity is relative to the RMS level of a sine wave with positive amplitude equal to 100% 1s density and negative amplitude equal to 0% 1s density.

**Note 2:** The sensitivity shall not deviate more than 1.0 dB from its initial value after reliability tests.

**Note 3:** See Figure 4.

**TABLE 5. DIGITAL INPUT/OUTPUT CHARACTERISTICS**
 $T_A = 25^\circ\text{C}$ ,  $1.8\text{ V} < V_{DD} < 3.3\text{ V}$ , unless otherwise noted.

PARAMETER	CONDITIONS	MIN	TYP	MAX	UNITS	NOTES
Input Voltage High ( $V_{IH}$ )		$0.65 \times V_{DD}$			V	
Input Voltage Low ( $V_{IL}$ )				$0.35 \times V_{DD}$	V	
Output Voltage High ( $V_{OH}$ )	$I_{LOAD} = 0.5\text{ mA}$	$0.7 \times V_{DD}$	$V_{DD}$		V	
Output Voltage Low ( $V_{OL}$ )	$I_{LOAD} = 0.5\text{ mA}$		0	$0.3 \times V_{DD}$	V	
Output DC Offset	Percent of full scale		3		%	
Latency			<30		$\mu\text{s}$	

**TABLE 6. PDM DIGITAL INPUT/OUTPUT**
 $T_A = 25^\circ\text{C}$ ,  $1.8\text{ V} < V_{DD} < 3.3\text{ V}$ , unless otherwise noted.

PARAMETER	CONDITIONS	MIN	TYP	MAX	UNITS	NOTES
<b>MODE SWITCHING</b>						
Sleep Time	Time from $f_{CLK}$ falling <200 kHz			1	ms	
Wake-Up Time	High-Performance & Standard modes, Sleep Mode to $f_{CLK} >1\text{ MHz}$ , output within 0.5 dB of final sensitivity, power on			20	ms	
Wake-Up Time	Low-Power Mode, Sleep Mode to $f_{CLK} >400\text{ kHz}$ , output within 0.5 dB of final sensitivity, power on			20	ms	
Switching time	Between Low-Power and Standard Modes			10	ms	
Switching time	Between Low-Power and High-Performance Modes			10	ms	
<b>INPUT</b>						
$t_{CLKIN}$	Input clock period	208		2500	ns	
Clock Frequency (CLK)	Sleep Mode			200	kHz	
	Low-Power Mode	400		800	kHz	
	Standard Mode	1.0		3.3	MHz	
	High-Performance Mode	4.1		4.8	MHz	
Clock Duty Cycle	$f_{CLK} <3.3\text{ MHz}$	40		60	%	
	$f_{CLK} >4.1\text{ MHz}$	48		52	%	
$t_{RISE}$	CLK rise time (10% to 90% level)			25	ns	1
$t_{FALL}$	CLK fall time (90% to 10% level)			25	ns	1
<b>OUTPUT</b>						
$t_{1OUTEN}$	DATA1 (right) driven after falling clock edge	50			ns	
$t_{1OUTDIS}$	DATA1 (right) disabled after rising clock edge	5		40	ns	
$t_{2OUTEN}$	DATA2 (left) driven after rising clock edge	50			ns	
$t_{2OUTDIS}$	DATA2 (left) disabled after falling clock edge	5		40	ns	

**Note 1:** Guaranteed by design

**TIMING DIAGRAM**

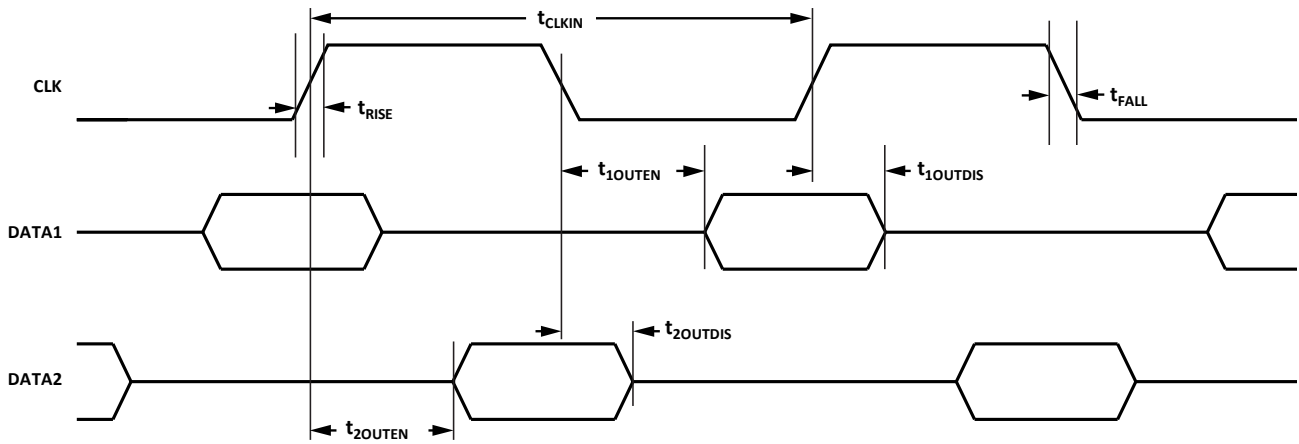

**Figure 1. Pulse Density Modulated Output Timing**

**ABSOLUTE MAXIMUM RATINGS**

Stress above those listed as Absolute Maximum Ratings may cause permanent damage to the device. These are stress ratings only and functional operation of the device at these conditions is not implied. Exposure to the absolute maximum ratings conditions for extended periods may affect device reliability.

**TABLE 7. ABSOLUTE MAXIMUM RATINGS**

PARAMETER	RATING
Supply Voltage ( $V_{DD}$ )	-0.3 V to +3.63 V
Digital Pin Input Voltage	-0.3 V to $V_{DD} + 0.3$ V or 3.63 V, whichever is less
Mechanical Shock	10,000 g
Vibration	Per MIL-STD-883 Method 2007, Test Condition B
Temperature Range	
Biased	-40°C to +85°C
Storage	-55°C to +150°C

**ESD CAUTION**



ESD (electrostatic discharge) sensitive device. Charged devices and circuit boards can discharge without detection. Although this product features patented or proprietary protection circuitry, damage may occur on devices subjected to high energy ESD. Therefore proper ESD precautions should be taken to avoid performance degradation or loss of functionality.



**SOLDERING PROFILE**

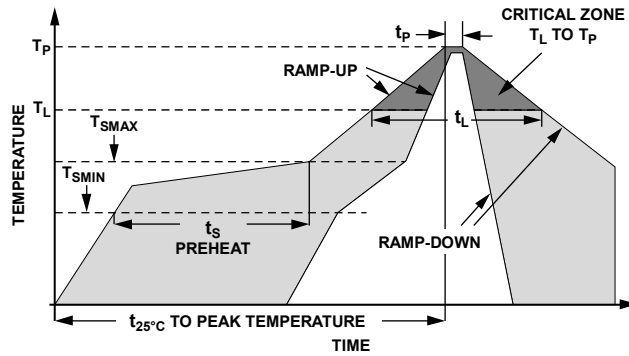

**Figure 2. Recommended Soldering Profile Limits**

**TABLE 8. RECOMMENDED SOLDERING PROFILE\***

PROFILE FEATURE		Sn63/Pb37	Pb-Free
Average Ramp Rate ( $T_L$ to $T_P$ )		1.25°C/sec max	1.25°C/sec max
Preheat	Minimum Temperature ( $T_{SMIN}$ )	100°C	100°C
	Maximum Temperature ( $T_{SMAX}$ )	150°C	200°C
	Time ( $T_{SMIN}$ to $T_{SMAX}$ ), $t_s$	60 sec to 75 sec	60 sec to 75 sec
Ramp-Up Rate ( $T_{SMAX}$ to $T_L$ )		1.25°C/sec	1.25°C/sec
Time Maintained Above Liquidous ( $t_L$ )		45 sec to 75 sec	~50 sec
Liquidous Temperature ( $T_L$ )		183°C	217°C
Peak Temperature ( $T_P$ )		215°C +3°C/-3°C	260°C +0°C/-5°C
Time Within +5°C of Actual Peak Temperature ( $t_p$ )		20 sec to 30 sec	20 sec to 30 sec
Ramp-Down Rate		3°C/sec max	3°C/sec max
Time +25°C ( $t_{25^\circ C}$ ) to Peak Temperature		5 min max	5 min max

*\*The reflow profile in Table 8 is recommended for board manufacturing with InvenSense MEMS microphones. All microphones are also compatible with the J-STD-020 profile*

**PIN CONFIGURATIONS AND FUNCTION DESCRIPTIONS**

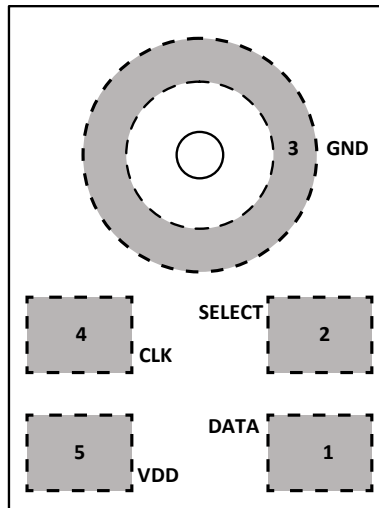

Figure 3. Pin Configuration (Top View, Terminal Side Down)

**TABLE 9. PIN FUNCTION DESCRIPTIONS**

PIN	NAME	FUNCTION
1	DATA	Digital Output Signal (DATA1 or DATA2)
2	SELECT	Left Channel or Right Channel Select: DATA 1 (right): SELECT tied to GND DATA 2 (left): SELECT tied to VDD. In this setting, SELECT should be tied to the same voltage source as the VDD pin.
3	GND	Ground
4	CLK	Clock Input to Microphone
5	VDD	Power Supply. For best performance and to avoid potential parasitic artifacts, place a 0.1 $\mu$ F (100 nF) ceramic type X7R capacitor between Pin 5 (VDD) and ground. Place the capacitor as close to Pin 5 as possible.

**TYPICAL PERFORMANCE CHARACTERISTICS**

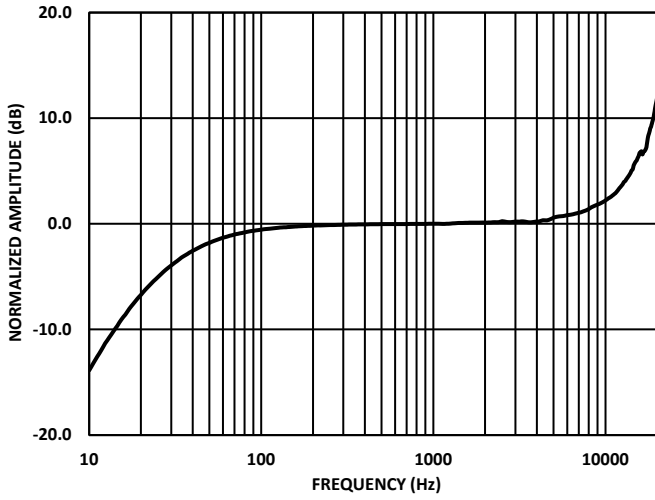

Figure 4. Typical Frequency Response

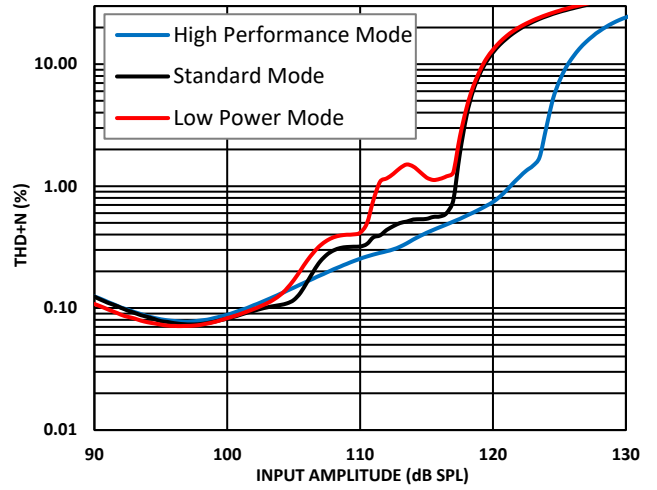

Figure 5. THD + N vs. Input Level

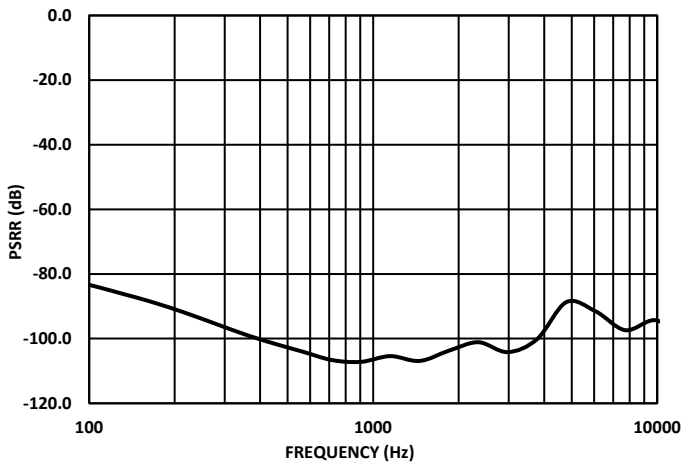

Figure 6. Power Supply Rejection (PSR) vs. Frequency

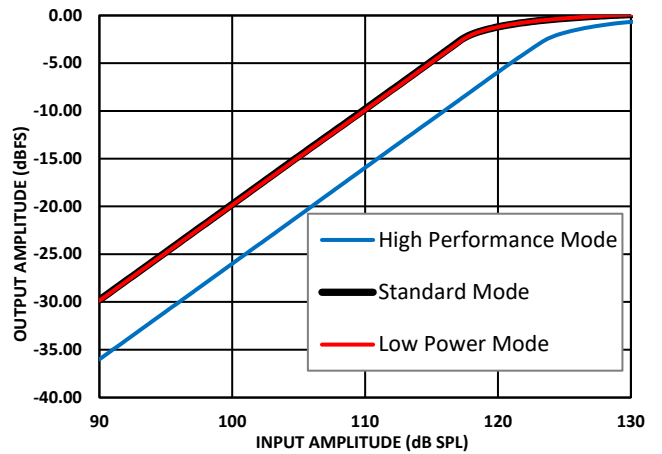
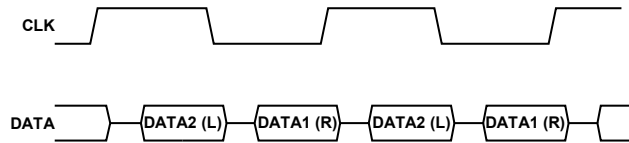

Figure 7. Linearity

## THEORY OF OPERATION

### PDM DATA FORMAT

The output from the DATA pin of the T3902 is in pulse density modulated (PDM) format. This data is the 1-bit output of a fourth-order  $\Sigma$ - $\Delta$  modulator. The data is encoded so that the left channel is clocked on the falling edge of CLK, and the right channel is clocked on the rising edge of CLK. After driving the DATA signal high or low in the appropriate half frame of the CLK signal, the DATA driver of the microphone tristates. In this way, two microphones, one set to the left channel and the other to the right, can drive a single DATA line. See Figure 1 for a timing diagram of the PDM data format; the DATA1 and DATA2 lines shown in this figure are two halves of the single physical DATA signal. Figure 8 shows a diagram of the two stereo channels sharing a common DATA line.



**Figure 8. Stereo PDM Format**

If only one microphone is connected to the DATA signal, the output is only clocked on a single edge (Figure 9). For example, a left channel microphone is never clocked on the rising edge of CLK. In a single microphone application, each bit of the DATA signal is typically held for the full CLK period until the next transition because the leakage of the DATA line is not enough to discharge the line while the driver is tristated.

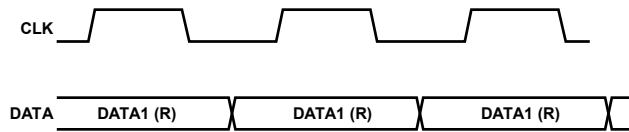

**Figure 9. Mono PDM Format**

See Table 10 for the channel assignments according to the logic level on the SELECT pin.

**TABLE 10. T3902 CHANNEL SETTING**

SELECT Pin Setting	Channel
Low (tie to GND)	Right (DATA1)
High (tie to VDD)	Left (DATA2)

For PDM data, the density of the pulses indicates the signal amplitude. A high density of high pulses indicates a signal near positive full scale, and a high density of low pulses indicates a signal near negative full scale. A perfect zero (dc) audio signal shows an alternating pattern of high and low pulses.

The output PDM data signal has a dc offset of about 3% of full scale. A high-pass filter in the codec that is connected to the digital microphone and does not affect the performance of the microphone typically removes this dc signal.

### PDM MICROPHONE SENSITIVITY

The sensitivity of a PDM output microphone is specified with the unit dB FS (decibels relative to digital full scale). A 0 dB FS sine wave is defined as a signal whose peak just touches the full-scale code of the digital word (see Figure 10). This measurement convention also means that signals with a different crest factor may have an RMS level higher than 0 dB FS. For example, a full-scale square wave has an RMS level of 3 dB FS.

This definition of a 0 dB FS signal must be understood when measuring the sensitivity of the T3902. A 1 kHz sine wave at a 94 dB SPL acoustic input to the T3902 results in an output signal with a -26 dB FS level in Standard Mode and -32 dB FS in High Performance Mode. In the Standard Mode example, the output digital word peaks at -26 dB below the digital full-scale level. A common

misunderstanding is that the output has an RMS level of  $-29$  dB FS; however, this is not true because of the definition of the 0 dB FS sine wave.

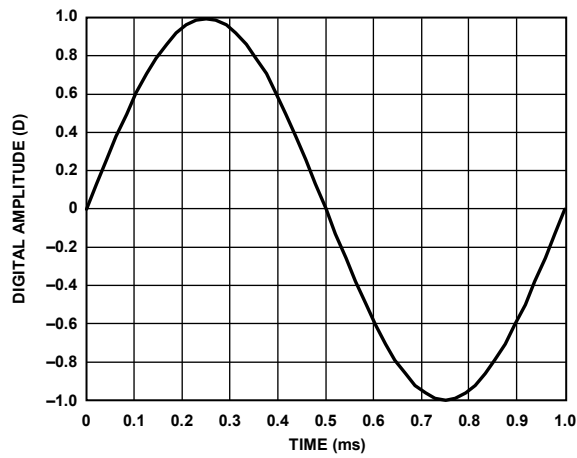

**Figure 10. 1 kHz, 0 dB FS Sine Wave**

There is not a commonly accepted unit of measurement to express the instantaneous level, as opposed to the RMS level of the signal, of a digital signal output from the microphone. Some measurement systems express the instantaneous level of an individual sample in units of D, where 1.0 D is digital full scale. In this case, a  $-26$  dB FS sine wave has peaks at 0.05 D.

## APPLICATIONS INFORMATION

### LOW POWER MODE

Low Power Mode (LPM) enables the T3902 to be used in an AlwaysOn listening mode for keyword spotting and ambient sound analysis. The T3902 will enter LPM when the frequency of SCK is between 400 and 800 kHz. In this mode, the microphone consumes only 185  $\mu$ A while retaining high electro-acoustic performance.

When one microphone is in LPM for AlwaysOn listening, a second microphone sharing the same data line may be powered down. In this case, where one microphone is powered up and another is powered down by disabling the VDD supply or in sleep mode by reducing the frequency of a separate clock source, the disabled microphone does not present a load to the signal on the LPM microphone's DATA pin.

### DYNAMIC RANGE CONSIDERATIONS

The full-scale digital output (0 dB FS) of the T3902 is mapped to an acoustic input of 126 dB SPL in high-performance mode. The microphone clips (THD = 10%) at 126 dB SPL (see Figure 5); however, it continues to output an increasingly distorted signal above that point. The peak output level, which is controlled by the modulator, limits at 0 dB FS (see Figure 7).

To fully use the 96 dB dynamic range of the output data of the T3902 in a design, the digital signal processor (DSP), analog-to-digital converter (ADC), or codec circuit following it must be chosen carefully. The decimation filter that inputs the PDM signal from the T3902 must have a dynamic range sufficiently better than the dynamic range of the microphone so that the overall noise performance of the system is not degraded. If the decimation filter has a dynamic range of 10 dB better than the microphone, the overall system noise only degrades by 0.4 dB. This 106 dB filter dynamic range requires the filter to have at least 18 bit resolution.

### CONNECTING PDM MICROPHONES

A PDM output microphone is typically connected to a codec with a dedicated PDM input. This codec separately decodes the left and right channels and filters the high sample rate modulated data back to the audio frequency band. This codec also generates the clock for the PDM microphones or is synchronous with the source that is generating the clock. Figure 11 and Figure 12 show mono and stereo connections of the T3902 to a codec. The mono connection shows an T3902 set to output data on the right channel. To output on the left channel, tie the SELECT pin to VDD instead of tying it to GND.

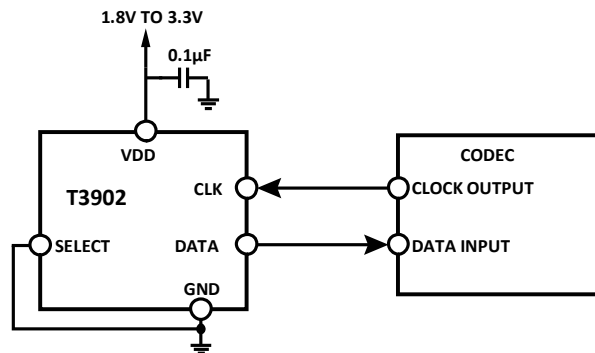
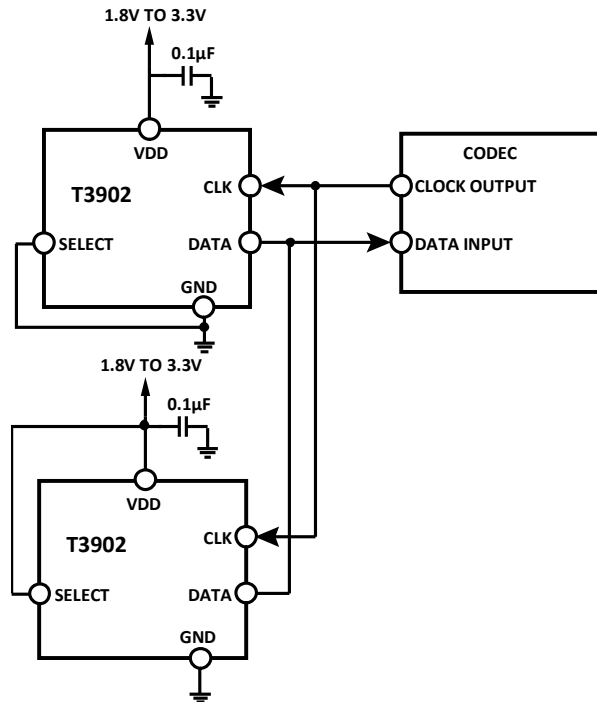

Figure 11. Mono PDM Microphone (Right Channel) Connection to Codec

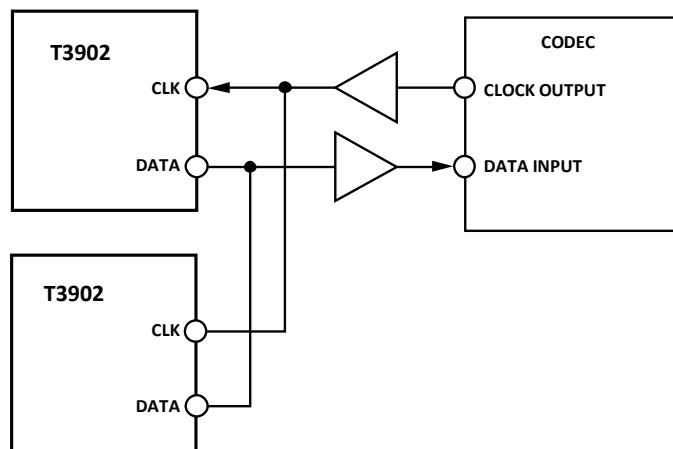

**Figure 12. Stereo PDM Microphone Connection to Codec**

Decouple the VDD pin of the T3902 to GND with a 0.1 µF capacitor. Place this capacitor as close to VDD as the printed circuit board (PCB) layout allows.

Do not use a pull-up or pull-down resistor on the PDM data signal line because it can pull the signal to an incorrect state during the period that the signal line is tristated.

The DATA signal does not need to be buffered in normal use when the T3902 microphone(s) is placed close to the codec on the PCB. If the DATA signal must be driven over a long cable (>15 cm) or other large capacitive load, a digital buffer may be required. Only use a signal buffer on the DATA line when one microphone is in use or after the point where two microphones are connected (see Figure 13). The DATA output of each microphone in a stereo configuration cannot be individually buffered because the two buffer outputs cannot drive a single signal line. If a buffer is used, take care to select one with low propagation delay so that the timing of the data connected to the codec is not corrupted.



**Figure 13. Buffered Connections Between Stereo T3902s and a Codec**

When long wires are used to connect the codec to the T3902, a source termination resistor can be used on the clock output of the codec instead of a buffer to minimize signal overshoot or ringing. Match the value of this resistor to the characteristic impedance of

the CLK trace on the PCB. Depending on the drive capability of the codec clock output, a buffer may still be needed, as shown in Figure 13.

## SLEEP MODE

The microphone enters sleep mode when the clock frequency falls below 200 kHz. In this mode, the microphone data output is in a high impedance state. The current consumption in sleep mode is less than 20  $\mu$ A.

The T3902 enters sleep mode within 1 ms of the clock frequency falling below 200 kHz. The microphone wakes up from sleep mode and begins to output data within 20 ms of when the clock becomes active.

In sleep mode:

If the SELECT signal is logic high, the DATA pin will be pulled low to GND.

If the SELECT signal is logic low, the DATA pin will be high impedance (floating).

CLK	SELECT	DATA
<200kHz or float	VDD	GND
<200kHz or float	GND	HiZ

## START-UP TIME

The start-up time of the T3902 is less than 20 ms. The PDM data from the microphone is valid to be used as soon as the data is being output.



---

## **SUPPORTING DOCUMENTS**

For additional information, see the following documents.

### **APPLICATION NOTES**

AN-000048, *PDM Digital Output MEMS Microphone Flex Evaluation Board User Guide*

AN-100, *MEMS Microphone Handling and Assembly Guide*

AN-1003, *Recommendations for Mounting and Connecting the InvenSense, Bottom-Ported MEMS Microphones*

AN-1112, *Microphone Specifications Explained*

AN-1124, *Recommendations for Sealing InvenSense Bottom-Port MEMS Microphones from Dust and Liquid Ingress*

AN-1140, *Microphone Array Beamforming*

### PCB DESIGN AND LAND PATTERN LAYOUT

The recommended PCB land pattern for the T3902 is a 1:1 ratio of the solder pads on the microphone package, as shown in Figure 14. Avoid applying solder paste to the sound hole in the PCB. A suggested solder paste stencil pattern layout is shown in Figure 15.

The response of the T3902 is not affected by the PCB hole size as long as the hole is not smaller than the sound port of the microphone (0.375 mm in diameter). A 0.5 mm to 1 mm diameter for the hole is recommended. Take care to align the hole in the microphone package with the hole in the PCB. The exact degree of the alignment does not affect the microphone performance as long as the holes are not partially or completely blocked.

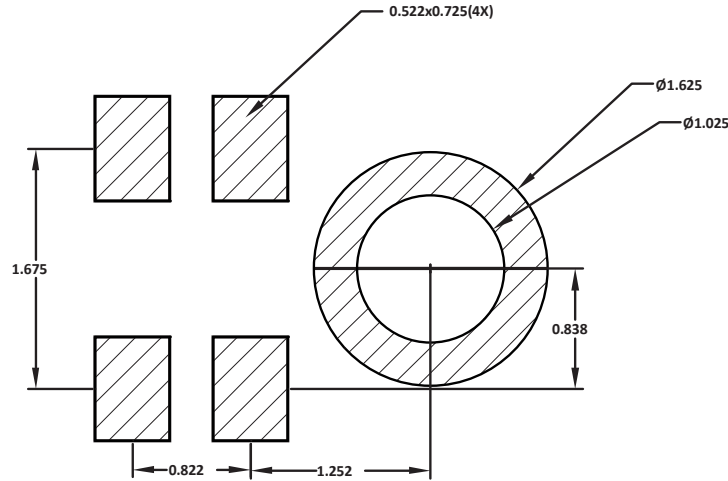

Figure 14. Recommended PCB Land Pattern Layout

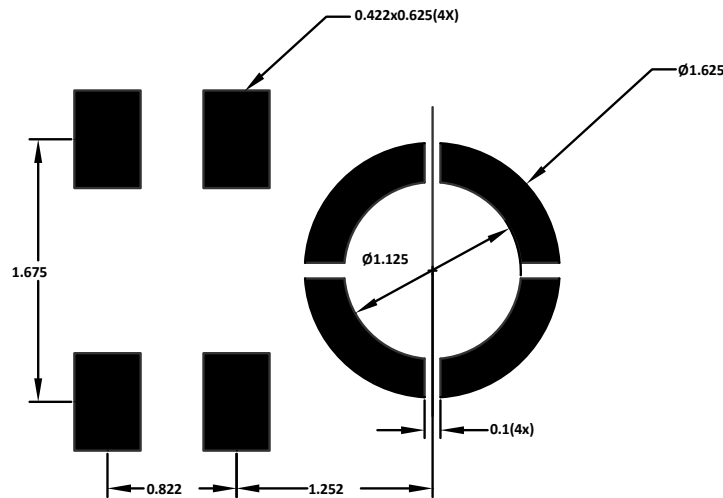

Figure 15. Suggested Solder Paste Stencil Pattern Layout

### PCB MATERIAL AND THICKNESS

The performance of the T3902 is not affected by PCB thickness. The T3902 can be mounted on either a rigid or flexible PCB. A flexible PCB with the microphone can be attached directly to the device housing with an adhesive layer. This mounting method offers a reliable seal around the sound port while providing the shortest acoustic path for good sound quality.

## **HANDLING INSTRUCTIONS**

### **PICK AND PLACE EQUIPMENT**

The MEMS microphone can be handled using standard pick-and-place and chip shooting equipment. Take care to avoid damage to the MEMS microphone structure as follows:

- Use a standard pickup tool to handle the microphone. Because the microphone hole is on the bottom of the package, the pickup tool can make contact with any part of the lid surface.
- Do not pick up the microphone with a vacuum tool that makes contact with the bottom side of the microphone. Do not pull air out of or blow air into the microphone port.
- Do not use excessive force to place the microphone on the PCB.

### **REFLOW SOLDER**

For best results, the soldering profile must be in accordance with the recommendations of the manufacturer of the solder paste used to attach the MEMS microphone to the PCB. It is recommended that the solder reflow profile not exceed the limit conditions specified in Figure 2 and Table 8.

### **BOARD WASH**

When washing the PCB, ensure that water does not make contact with the microphone port. Do not use blow-off procedures or ultrasonic cleaning.

**OUTLINE DIMENSIONS**

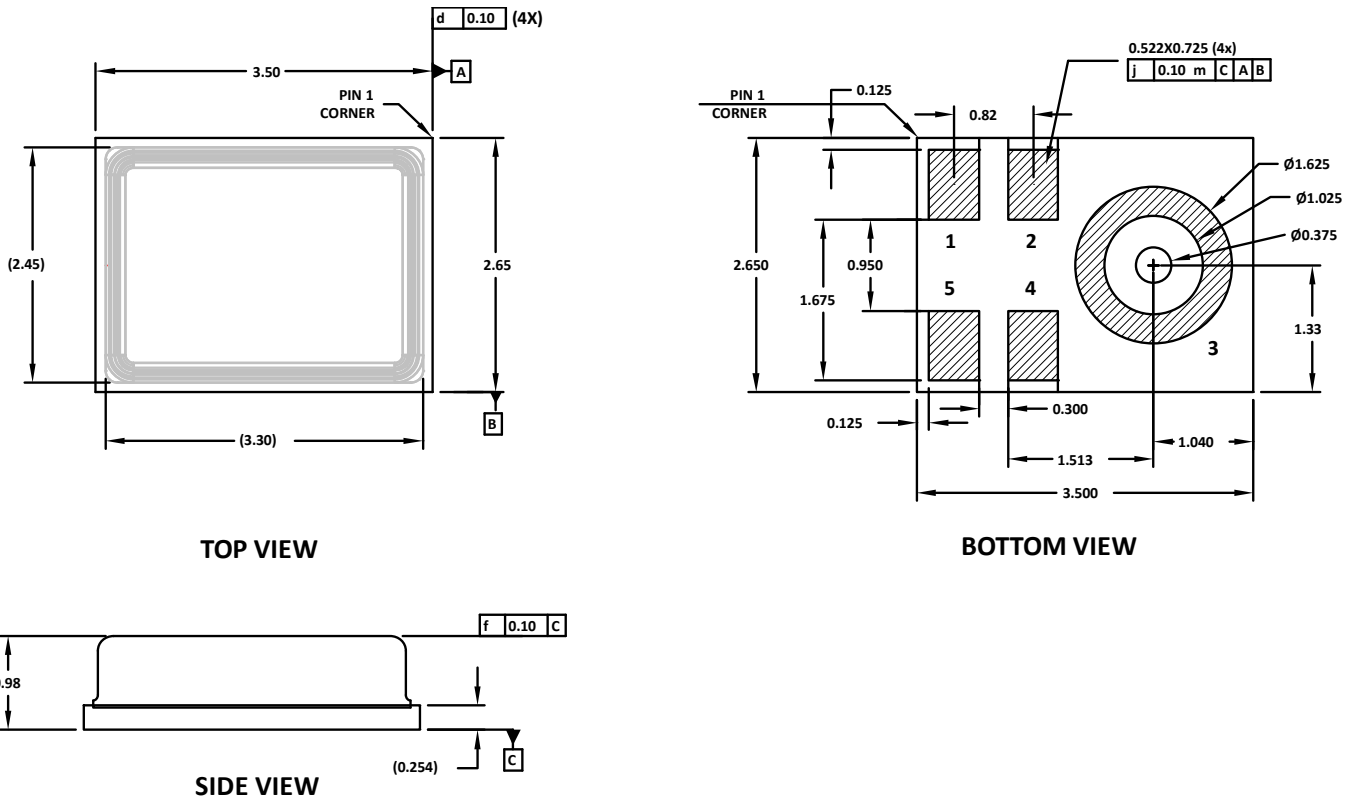

**Figure 16. 5-Terminal Chip Array Small Outline No Lead Cavity [LGA\_CAV]**  
**3.5 mm × 2.65 mm × 0.98 mm Body**  
**Dimensions shown in millimeters**  
**Dimension tolerance is ±0.15 mm unless otherwise specified**

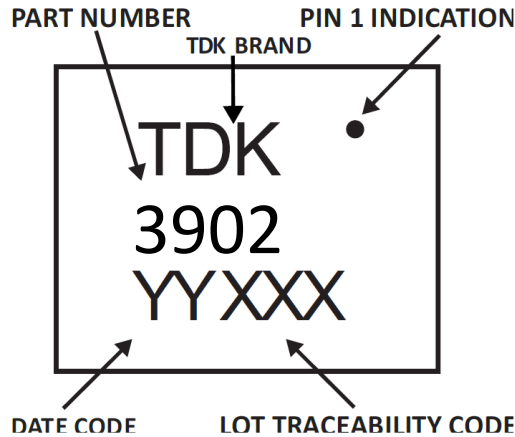

**Figure 17. Package Marking Specification (Top View)**

**ORDERING GUIDE**

PART	TEMP RANGE	PACKAGE	QUANTITY	PACKAGING
MMICT3902-00-012	-40°C to +85°C	5-Terminal LGA_CAV	10,000	13" Tape and Reel
EV_T3902-FX	—	Evaluation Board	—	

**REVISION HISTORY**

REVISION DATE	REVISION	DESCRIPTION
12/16/2019	0.1	Initial version
2/12/2020	0.2	Updated Package Marking Specification
4/15/2020	1.0	Initial release

## **COMPLIANCE DECLARATION DISCLAIMER**

InvenSense believes the environmental and other compliance information given in this document to be correct but cannot guarantee accuracy or completeness. Conformity documents substantiating the specifications and component characteristics are on file. InvenSense subcontracts manufacturing, and the information contained herein is based on data received from vendors and suppliers, which has not been validated by InvenSense.

This information furnished by InvenSense, Inc. ("InvenSense") is believed to be accurate and reliable. However, no responsibility is assumed by InvenSense for its use, or for any infringements of patents or other rights of third parties that may result from its use. Specifications are subject to change without notice. InvenSense reserves the right to make changes to this product, including its circuits and software, in order to improve its design and/or performance, without prior notice. InvenSense makes no warranties, neither expressed nor implied, regarding the information and specifications contained in this document. InvenSense assumes no responsibility for any claims or damages arising from information contained in this document, or from the use of products and services detailed therein. This includes, but is not limited to, claims or damages based on the infringement of patents, copyrights, mask work and/or other intellectual property rights.

Certain intellectual property owned by InvenSense and described in this document is patent protected. No license is granted by implication or otherwise under any patent or patent rights of InvenSense. This publication supersedes and replaces all information previously supplied. Trademarks that are registered trademarks are the property of their respective companies. InvenSense sensors should not be used or sold in the development, storage, production or utilization of any conventional or mass-destructive weapons or for any other weapons or life threatening applications, as well as in any other life critical applications such as medical equipment, transportation, aerospace and nuclear instruments, undersea equipment, power plant equipment, disaster prevention and crime prevention equipment.

©2019 InvenSense. All rights reserved. InvenSense, MotionTracking, MotionProcessing, MotionProcessor, MotionFusion, MotionApps, DMP, AAR, and the InvenSense logo are trademarks of InvenSense, Inc. The InvenSense logo is a trademark of InvenSense Corporation. Other company and product names may be trademarks of the respective companies with which they are associated.