

DESCRIPTION: HIGH DENSITY FEMALE - VERTICAL DIP SOLDER

DIMENSIONS

Insulator Material	No. OF PINS	A	B	C	D	E	F	G	H
PA9T	15	1.213	0.984	0.643	0.311	0.090	0.756	0.496	0.429
		30.80	24.99	16.34	7.90	2.29	19.20	12.60	10.90
PA9T	26	1.543	1.312	0.972	0.311	0.090	1.091	0.496	0.429
		39.20	33.32	24.70	7.90	2.29	27.70	12.60	10.90
PA9T	44	2.087	1.852	1.512	0.311	0.090	1.618	0.496	0.429
		53.00	47.04	38.40	7.90	2.29	41.10	12.60	10.90
PA6T	62	2.732	2.500	2.157	0.311	0.095	2.256	0.496	0.429
		69.40	63.50	54.80	7.90	2.41	57.30	12.60	10.90
PA6T	78	2.638	2.406	2.055	0.429	0.095	2.169	0.606	0.526
		67.00	61.10	52.20	10.90	2.41	55.10	15.40	13.35

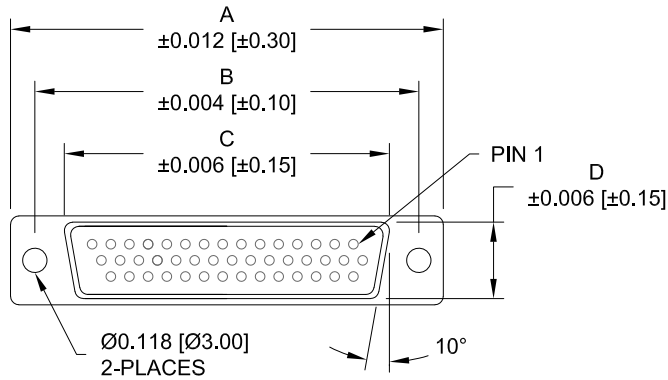

4 ROWS

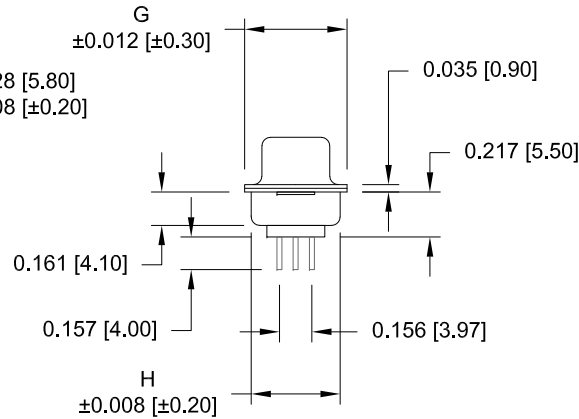
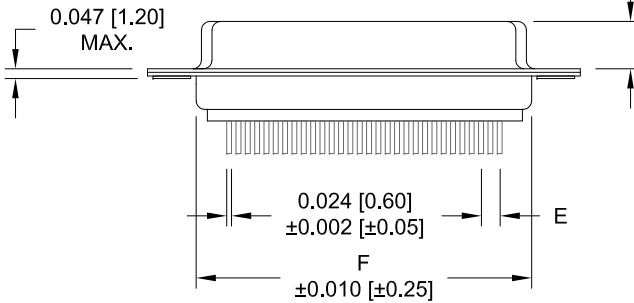

180-YYY-213RYY1

- SERIES
- POSITIONS
 - 015
 - 026
 - 044
 - 062
 - 078
- GENDER
- TERMINATION
 - 2 = FEMALE
 - 1 = VERTICAL DIP SOLDER
- SHELL PLATING
 - 2 = TIN
 - 3 = NICKEL
- RoHS COMPLIANT (260°C)
- HARDWARE OPTIONS
 - 00 = NO HARDWARE
 - 01 = .098" CLINCH NUT (BOARD SIDE)
 - 02 = .236" CLINCH NUT (BOARD SIDE)
 - 03 = .236" CLINCH NUT (MATING SIDE)
 - 05 = .237" 4-40 BOARD LOCK
 - 08 = .224" 4-40 BOARD LOCK
 - 90 = .237" 4-40 BOARD LOCK
 - FOR 0.093" BOARD MAX.
 - 91 = .237" 4-40 SPACER/BOARD LOCK
 - 92 = .237" 4-40 SPACER/BOARD LOCK
 - FOR 0.093" BOARD MAX.
- PLATING OPTIONS
 - 1 = GOLD FLASH
 - A = 30u" GOLD MATING AREA, GOLD FLASH OVERALL

MATERIAL:

- SHELL: STEEL, NICKEL PLATED
- INSULATOR: GLASS FILLED THERMOPLASTIC, UL 94V-O RATED
- CONTACT: BRASS, GOLD PLATED OVER NICKEL

ELECTRICAL:

- CURRENT RATING: 3 AMPS
- CONTACT RESISTANCE: 15 mOhms Max.
- INSULATION RESISTANCE: 1,000 MOhms min.
- VOLTAGE: 500VAC FOR 1 MINUTE
- TEMPERATURE: -50° C TO 100° C

DO NOT SCALE FROM DRAWING



THESE DRAWINGS AND SPECIFICATIONS ARE THE PROPERTY OF NorComp AND SHALL NOT BE REPRODUCED, COPIED OR USED AS THE BASIS FOR THE MANUFACTURE OF SALE OF APPARATUS WITHOUT WRITTEN PERMISSION.

DRAWN:		DATE:	
PAM JENKINS		09-12-05	

NorComp

SCALE:	SHEET	OF	REV
NTS	1	3	23
DWG NO.		180-YYY-213RYY1	

RoHS COMPLIANT

DESCRIPTION: PCB LAYOUT - VERTICAL - FEMALE

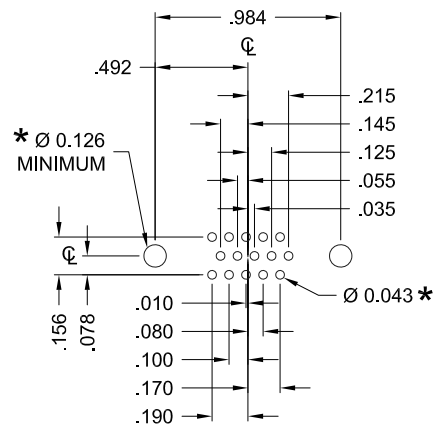

15 POSITION

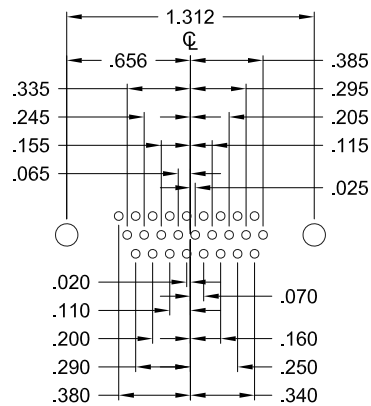

26 POSITION

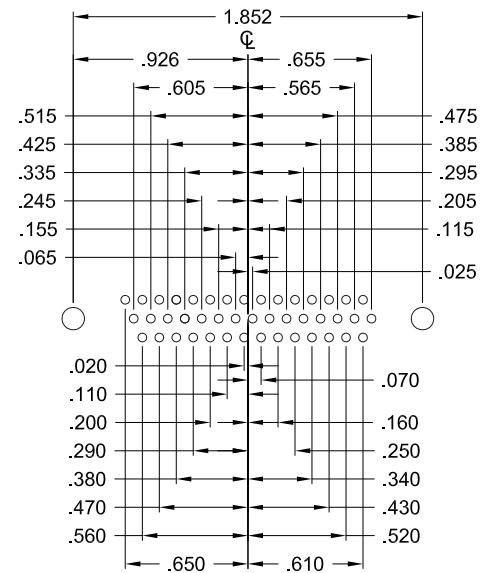

44 POSITION

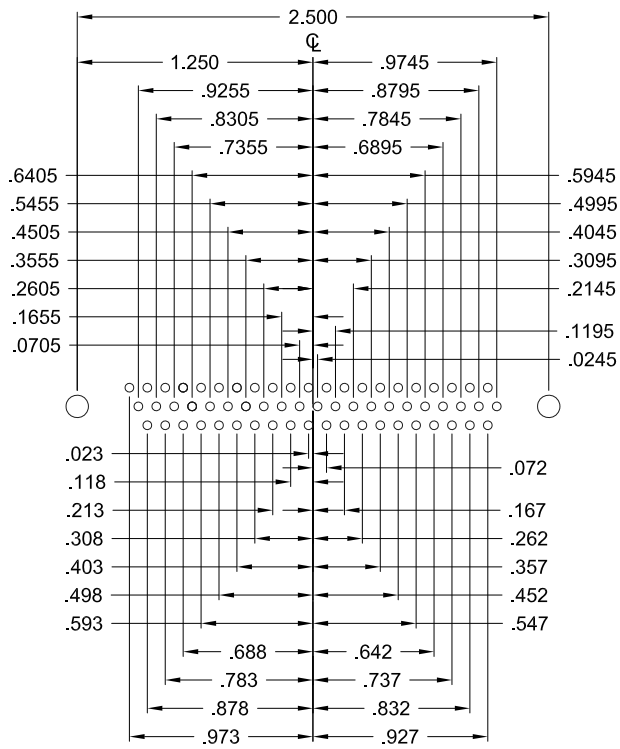

62 POSITION

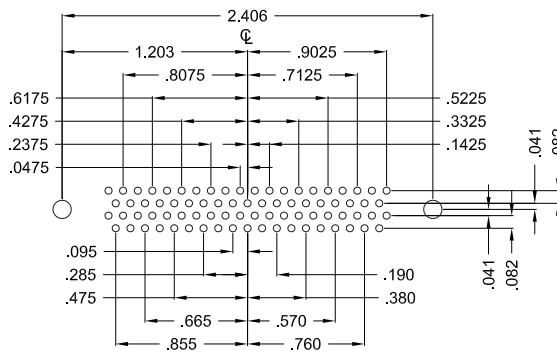

78 POSITION

HOLE PATTERN SHOWN ARE FOR FEMALE

UNITS = inch

* TYP. SUGGESTED SIZE MAY NOT BE SUITABLE FOR ALL APPLICATIONS

DO NOT SCALE FROM DRAWING



THESE DRAWINGS AND SPECIFICATIONS ARE THE PROPERTY OF NorComp AND SHALL NOT BE REPRODUCED, COPIED OR USED AS THE BASIS FOR THE MANUFACTURE OF SALE OF APPARATUS WITHOUT WRITTEN PERMISSION.

NorComp

DRAWN: PAM JENKINS		DATE: 09-12-05	
SCALE: NTS	SHEET 2	OF 3	REV 23
DWG NO. 180-YYY-213RYY1			

ALL CLINCH-NUTS ARE 4-40 INTERNAL THREADS

01X 0.098" (BOARD SIDE)

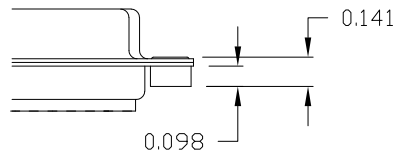

02X 0.236" (BOARD SIDE)

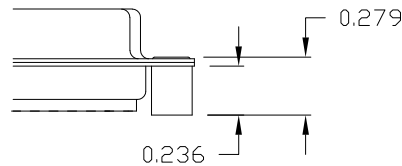

03X..... 0.236" (MATING SIDE)

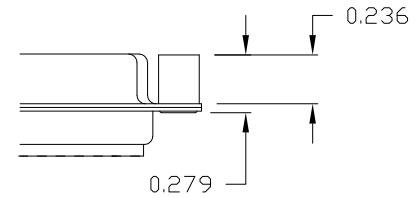

05X 0.237" (BOARD SIDE)

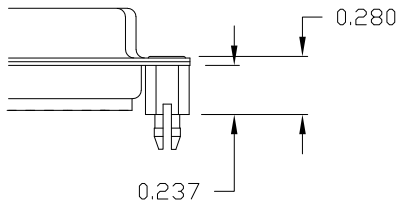

08X 0.228" (BOARD SIDE)

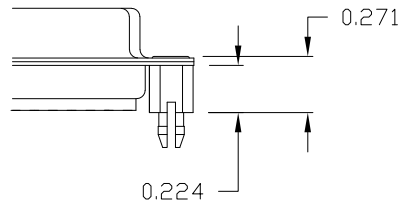

91X 0.237" BOARD SIDE

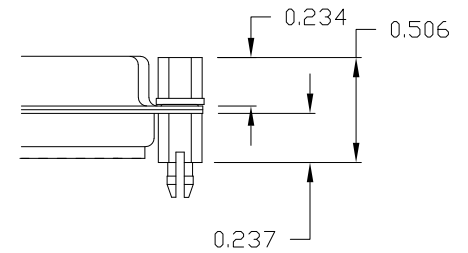

NOTE: 4-40 FEMALE SCREW LOCK IS REMOVABLE

90X 0.237" (BOARD SIDE)

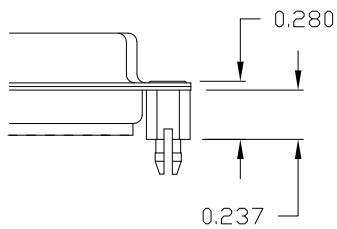

92X 0.237" BOARD SIDE

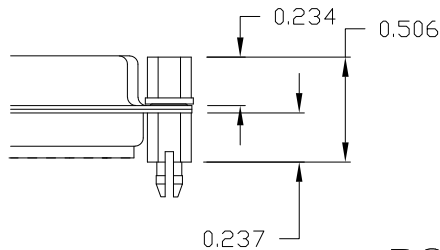

NOTE: 4-40 FEMALE SCREW LOCK IS REMOVABLE

NOTE: 90 & 92 OPTION FOR 0.093" MAX. BOARD THICKNESS

TOLERANCE:

ALL DIMENSIONS ARE ±0.010

DO NOT SCALE FROM DRAWING

RoHS COMPLIANT



THESE DRAWINGS AND SPECIFICATIONS ARE THE PROPERTY OF NorComp AND SHALL NOT BE REPRODUCED, COPIED OR USED AS THE BASIS FOR THE MANUFACTURE OF SALE OF APPARATUS WITHOUT WRITTEN PERMISSION.

NorComp

DRAWN: PAM JENKINS		DATE: 09-12-05	
SCALE: NTS	SHEET 3	OF 3	REV 23
DWG NO. 180-YYY-213RYY1			