

---

---

**SAM-IoT Wx Hardware User Guide**

---

---

**Preface**

---



**Important:** This document is applicable for the SAM-IoT WG development board, which is preconfigured to send data through the Google Cloud™ IoT Core. It can be reconfigured to send data to different cloud providers.

---

The SAM-IoT Wx development board is a small and easily expandable demonstration and development platform for IoT solutions, based on the SAM® microcontroller architecture using Wi-Fi® technology. The development board is designed to demonstrate the design of a typical IoT application which can be simplified by dividing the problem into these blocks:

- **Smart:** Represented by the [ATSAMD21G18A](#) microcontroller
- **Secure:** Represented by the [ATECC608A](#) secure element
- **Connected:** Represented by the [ATWINC1510](#) Wi-Fi controller module

The SAM-IoT Wx development board features the following elements, as shown in the following figure.

- The on-board debugger (nEDBG) supplies full programming and debugging support through MPLAB® X IDE. It also provides access to a serial port interface (serial to USB bridge) and one logic analyzer channel (debug GPIO).
- The on-board debugger enumerates on the PC as a mass storage interface device for easy drag-and-drop programming, Wi-Fi configuration, and full access to the microcontroller application Command Line Interface (CLI).
- A mikroBUS™ socket allows for the ability to expand the board capabilities with the selection from 450+ sensors and actuators options offered by MikroElektronika ([www.mikroe.com](http://www.mikroe.com)) through a growing portfolio of Click boards™.
- A light sensor is used to demonstrate the published data.
- Microchip [MCP9808](#) high-accuracy temperature sensor used to demonstrate published data.
- Microchip [MCP73871](#) Li-Ion/Li-Polymer battery charger with power path management.
- [MPLAB® X IDE](#) Software to discover, configure, develop, program, and debug Microchip microcontrollers.



## Table of Contents

Preface.....	1
1. Introduction.....	4
1.1. Features.....	4
1.2. Board Overview.....	4
2. Getting Started.....	6
2.1. Quick Start.....	6
2.2. Design Documentation and Relevant Links.....	6
3. Application User Guide.....	7
4. Hardware User Guide.....	8
4.1. On-Board Debugger Overview.....	8
4.2. On-Board Debugger Connections.....	12
4.3. Power.....	13
4.4. Components.....	15
5. Regulatory Approval.....	19
5.1. United States.....	19
5.2. Canada.....	19
5.3. Taiwan.....	19
5.4. List of Antenna Types.....	20
6. Hardware Revision History.....	21
6.1. Identifying Product ID and Revision.....	21
7. Appendix.....	22
7.1. Schematics.....	22
7.2. Assembly Drawing.....	25
7.3. Mechanical Drawings.....	25
7.4. Bill of Materials.....	27
8. Revision History.....	28
The Microchip Website.....	29
Product Change Notification Service.....	29
Customer Support.....	29
Microchip Devices Code Protection Feature.....	29
Legal Notice.....	29
Trademarks.....	30
Quality Management System.....	30
Worldwide Sales and Service.....	31

## 1. Introduction

### 1.1 Features

- [ATSAMD21G18A](#) Arm® Cortex®-M0+ microcontroller
- [ATWINC1510](#) Wi-Fi module
- [ATECC608A](#) CryptoAuthentication™ device
- Pre-configured for Microchip accounts with cloud service providers
  - Google Cloud IoT Core
- Four user LEDs
- Two mechanical buttons
- TEMT6000 light sensor
- [MCP9808](#) temperature sensor
- mikroBUS socket
- On-board debugger
  - Board identification in Microchip MPLAB X IDE
  - One green board power and status LED
  - Virtual serial port (USB CDC)
  - One logic analyzer channels (debug GPIO)
- USB and battery powered
- [MCP73871](#) Li-Ion/Li-Polymer battery charger
- Fixed 3.3V

### 1.2 Board Overview

The SAM-IoT Wx development board is a hardware platform used to evaluate and develop IoT solutions with the Microchip ATSAMD21G18 Arm Cortex-M0+ based Flash microcontroller, ATECC608A secure element, and ATWINC1510 Wi-Fi controller module.

The pre-programmed demonstration application publishes data from the on-board light and temperature sensors read by the ATSAMD21G18A MCU to the cloud (every second). Any data received from the cloud over the subscribed topic is sent to the virtual serial port and can be displayed in a serial terminal application. The ATWINC1510 needs a connection to the Wi-Fi network with an internet connection. The ATECC608A is used to authenticate the hardware with the cloud to uniquely identify every board. The demonstration application source code can be modified to publish data to a personal cloud account to get started with a custom cloud application.

The following figure shows the key features and pinout of the SAM-IoT Wx development board.

Figure 1-1. SAM-IoT Wx Development Board

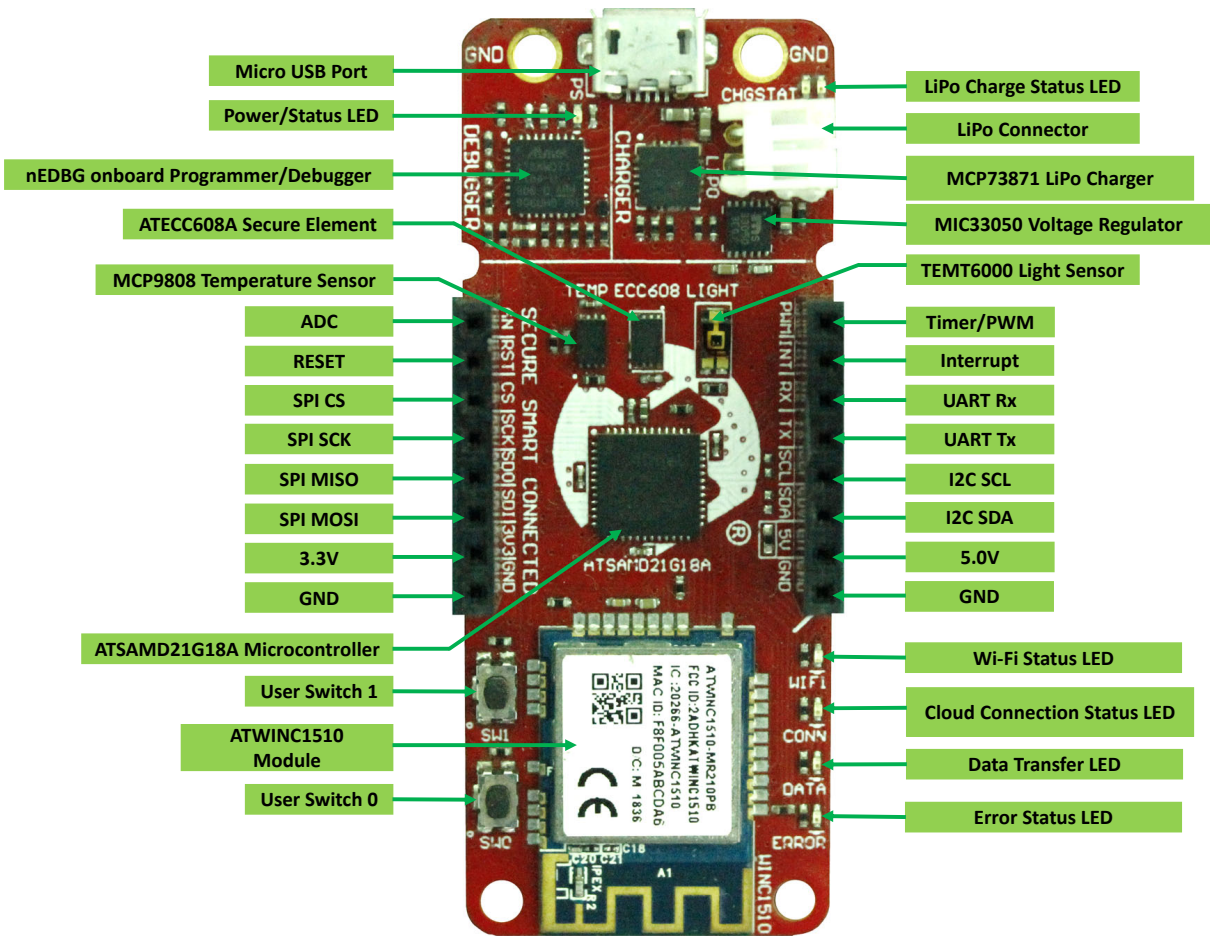

## 2. Getting Started

### 2.1 Quick Start

Follow these steps to exploring the SAM-IoT Wx development board:

1. Connect the SAM-IoT Wx development board to the computer.
2. Open the `CLICK-ME.HTM` file on the CURIOSITY mass storage disk and perform these actions:
  - 2.1. Download the latest application `.hex` firmware.
  - 2.2. Download the Wi-Fi configuration file `WIFI.cfg`.
3. Drag-and-drop the application `.hex` file on the CURIOSITY drive.
4. Drag-and-drop the `WIFI.cfg` configuration file on the CURIOSITY drive.

The development board will connect to the Wi-Fi network and send data to the website opened in step two through a cloud provider.

### 2.2 Design Documentation and Relevant Links

The following list provides links to the relevant documents and software for the SAM-IoT Wx development board.

- [MPLAB Data Visualizer](#) : A program used for processing and visualizing data. The Data Visualizer can receive data from various sources, such as serial ports and the on-board debugger's Data Gateway Interface, as found on the Curiosity Nano and Xplained Pro boards.
- [MPLAB® X IDE](#) : A software program that runs on a PC (Windows®, Mac OS®, Linux®) to develop applications for Microchip microcontrollers and digital signal controllers. It is called as Integrated Development Environment (IDE) because it provides a single integrated environment to develop code for embedded microcontrollers.
- [Microchip Sample Store](#) : Users can order device samples here.

### 3. Application User Guide

The ATSAMD21G18A is mounted on the SAM-IoT Wx development board, and is pre-programmed with an application ready to publish data to a Microchip account with a cloud service provider, and subscribe to data sent from [sam-iot.com](https://sam-iot.com) through the cloud service provider. The SAM-IoT WG development board is pre-configured for Google Cloud IoT Core. The data is read from the cloud and presented to the user on [sam-iot.com](https://sam-iot.com).

The latest firmware and application user's guide are available in the [EV75S95A kit page](#).

## 4. Hardware User Guide

### 4.1 On-Board Debugger Overview

The SAM-IoT Wx development board contains an on-board debugger for programming and debugging. The on-board debugger is a composite USB device consisting of several interfaces:

- A debugger that can program and debug the ATSAM21G18A in MPLAB X IDE.
- A mass storage device that allows drag-and-drop programming of the ATSAM21G18A.
- A virtual serial port (CDC) that is connected to a Universal Asynchronous Receiver/Transmitter (UART) on the ATSAM21G18A, and provides an easy way to communicate with the target application through terminal software.
- A Data Gateway Interface (DGI) for code instrumentation with logic analyzer channels (debug GPIO) to visualize program flow.

The on-board debugger controls a Power and Status LED (marked PS) on the SAM-IoT Wx development board. The following table shows how the LED is controlled in different operation modes.

**Table 4-1. On-Board Debugger Overview**

Operation Mode	Power and Status LED
Boot Loader mode	The LED blinks slowly during power-up.
Power-up	The LED is ON.
Normal operation	The LED is ON.
Programming	Activity indicator: The LED blinks slowly during programming/debugging.
Drag-and-drop programming	Success: The LED blinks slowly for 2 sec. Failure: The LED blinks rapidly for 2 sec.
Fault	The LED blinks rapidly if a power fault is detected.
Sleep/Off	The LED is OFF. The on-board debugger is either in Sleep mode or powered-down. This can occur if the board is externally powered.

**Info:** Slow blinking is approximately 1 Hz, and rapid blinking is approximately 5 Hz.

#### 4.1.1 Debugger

The on-board debugger on the SAM-IoT Wx development board appears as a mass storage with CDC on the host computer's USB subsystem. The debugger supports full-featured programming and debugging of the ATSAM21G18A using MPLAB X IDE or some third-party IDEs.



**Remember:** Ensure that the debugger's firmware is up-to-date. Firmware upgrades are done automatically when using MPLAB X IDE.

#### 4.1.2 Virtual Serial Port (CDC)

The virtual serial port (CDC) is a general purpose serial bridge between a host PC and a target device.

##### 4.1.2.1 Overview

The on-board debugger implements a composite USB device that includes a standard Communications Device Class (CDC) interface, which appears on the host as a virtual serial port. The CDC can be used to stream arbitrary data in both directions between the host computer and the target: All characters sent through the virtual serial port on the



host computer will be transmitted as UART on the debugger's CDC TX pin, and UART characters captured on the debugger's CDC RX pin will be returned to the host computer through the virtual serial port.

**Figure 4-1. CDC Connection**

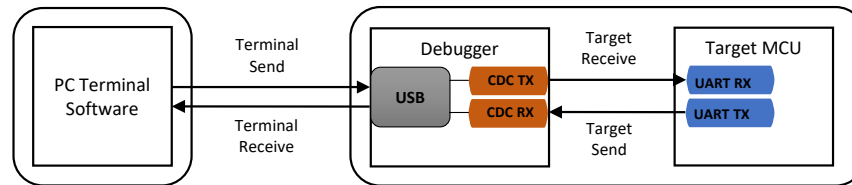

**Info:** As shown above, the debugger's CDC TX pin is connected to a UART RX pin on the target for receiving characters from the host computer. Similarly, the debugger's CDC RX pin is connected to a UART TX pin on the target for transmitting characters to the host computer.

### 4.1.2.2 Operating System Support

On Windows machines, the CDC will enumerate as Curiosity Virtual COM Port and appear in the Ports section of the Windows Device Manager. The COM port number can also be found there.



**Important:** On older Windows systems, a USB driver is required for CDC. This driver is included in installations of MPLAB X IDE.

On Linux machines, the CDC will enumerate and appear as `/dev/ttyACM#`.



**Important:** `tty*` devices belong to the `dialout` group in Linux, hence it may be necessary to become a member of that group to have permissions to access the CDC.

On MAC machines, the CDC will enumerate and appear as `/dev/tty.usbmodem#`. Depending on which terminal program is used, it will appear in the available list of modems as `usbmodem#`.



**Important:** For all operating systems, ensure to use a terminal emulator that supports DTR signaling. For additional information, refer to [Signaling](#).

### 4.1.2.3 Limitations

Not all UART features are implemented in the on-board debugger CDC. The constraints are outlined here:

- Baud rate: Must be in the range of 1200 bps to 500 kbps. Any baud rate outside this range will be set to the closest limit, without warning. Baud rate can be changed on-the-fly.
- Character format: Only 8-bit characters are supported.
- Parity: Can be odd, even, or none.
- Hardware flow control: Not supported.
- Stop bits: One or two bits are supported.

### 4.1.2.4 Signaling

During USB enumeration, the host OS will start both communication and data pipes of the CDC interface. At this point, it is possible to set and read back the baud rate and other UART parameters of the CDC, but data sending and receiving will not be enabled.

When a terminal connects on the host, it must assert the DTR signal. As this is a virtual control signal implemented on the USB interface, it is not physically present on the board. Asserting the DTR signal from the host will indicate to

the on-board debugger that a CDC session is active. The debugger will then enable its level shifters (if available), and start the CDC data send and receive mechanisms.

Deasserting the DTR signal will not disable the level shifters but will disable the receiver, hence no further data will be streamed to the host. Data packets that are already queued up for sending to the target will continue to be sent out, but no further data will be accepted.



**Remember:** Set up the terminal emulator to assert the DTR signal. Without the signal, the on-board debugger will not send or receive any data through its UART.



**Tip:** The on-board debugger's CDC TX pin will not be driven until the CDC interface is enabled by the host computer. Also, no external pull-up resistors on the CDC lines connecting the debugger and the target, which means that during power-up, these lines are floating. To avoid any glitches resulting in unpredictable behavior like framing errors, the target device must enable the internal pull-up resistor on the pin connected to the debugger's CDC TX pin.

### 4.1.2.5 Advanced Use

#### CDC Override Mode

In normal operation, the on-board debugger is a true UART bridge between the host and the device. However, in certain use cases, the on-board debugger can override the basic operating mode and use the CDC TX and RX pins for other purposes.

Dropping a text file into the on-board debugger's mass storage drive can be used to send characters out of the debugger's CDC TX pin. The file name and extension are trivial, but the text file must start with the characters:

```
CMD:SEND_UART=
```

The maximum message length is 50 characters. All remaining data in the frame is ignored.

The default baud rate used in this mode is 9600 bps, but if the CDC is already active or has been configured, the previously used baud rate still applies.

#### USB-Level Framing Considerations

Sending data from the host to the CDC can be done byte-wise or in blocks, which will be chunked into 64-byte USB frames. Each such frame will be queued up for sending to the debugger's CDC TX pin. Transferring a small amount of data per frame can be inefficient, particularly at low-baud rates, because the on-board debugger buffers frames and not bytes. A maximum of four 64-byte frames can be active at any time. The on-board debugger will throttle the incoming frames accordingly. Sending full 64-byte frames containing data is the most efficient method.

When receiving data on the debugger's CDC RX pin, the on-board debugger will queue up the incoming bytes into 64-byte frames, which are sent to the USB queue for transmission to the host when they are full. Incomplete frames are also pushed to the USB queue at approximately 100 ms intervals, triggered by USB start-of-frame tokens. Up to eight 64-byte frames can be active at any time.

If the host (or the software running on it) fails to receive data fast enough, an overrun will occur. When this happens, the last-filled buffer frame will be recycled instead of being sent to the USB queue, and a full frame of data will be lost. To prevent this occurrence, the user must ensure that the CDC data pipe is being read continuously, or the incoming data rate must be reduced.

### 4.1.3 Mass Storage Device

The on-board debugger includes a simple mass storage device implementation, which is accessible for read/write operations through the host operating system to which it is connected.

The mass storage device provides the following:

- Read access to basic text and HTML files for detailed kit information and support.

- Write access for programming Intel® HEX formatted files into the target device's memory.
- Write access for simple text files for utility purposes.

### 4.1.3.1 Mass Storage Device Implementation

The on-board debugger implements a highly optimized variant of the FAT12 file system that has several limitations, partly due to the nature of FAT12 itself and optimizations made to fulfill its purpose for its embedded application.

The Curiosity Nano USB Device is USB Chapter 9 compliant as a mass storage device but does not, in any way, fulfill the expectations of a general purpose mass storage device. This behavior is intentional.

When using the Windows operating system, the on-board debugger enumerates as a Curiosity Nano USB Device that can be found in the disk drives section of the device manager. The CURIOSITY drive appears in the file manager and claims the next available drive letter in the system.

The CURIOSITY drive contains approximately 1 MB of free space. This does not reflect the size of the target device's Flash in any way. When programming an Intel® HEX file, the binary data are encoded in ASCII with metadata providing a large overhead, hence 1 MB is a trivially chosen value for disk size.

It is not possible to format the CURIOSITY drive. When programming a file to the target, the file name may appear in the disk directory listing. This is merely the operating system's view of the directory, which, in reality, has not been updated. It is not possible to read out the file contents. Removing and replugging the board will return the file system to its original state, but the target will still contain the application that has been previously programmed.

To erase the target device, copy a text file starting with `CMD:ERASE` onto the disk.

By default, the CURIOSITY drive contains several read-only files for generating icons as well as reporting status and linking to further information:

- `AUTORUN.ICO`: Icon file for the Microchip logo
- `AUTORUN.INF`: System file required for Windows Explorer to show the icon file
- `CLICK-ME.HTM`: Redirect to the SAM-IoT WG web demo application
- `KIT-INFO.HTM`: Redirect to the development board website
- `KIT-INFO.TXT`: Text file containing details about the board's debugger firmware version, board name, USB serial number, device, and drag-and-drop support
- `PUBKEY.TXT`: Text file containing the public key for data encryption
- `STATUS.TXT`: Text file containing the programming status of the board

**Info:** The `STATUS.TXT` file is dynamically updated by the on-board debugger. The contents may be cached by the OS, therefore, do not reflect the correct status.

### 4.1.3.2 Limitations of Drag-and-Drop Programming

The NVM User Row bits included in the hex file will be ignored when using the drag-and-drop programming. However, the NVM User Row bits can be programmed using MPLAB X IDE.

### 4.1.3.3 Special Commands

Several utility commands are supported by copying text files to the mass storage disk. The file name or extension is irrelevant as the command handler reacts to content only.

**Table 4-2. Special File Commands**

Command Content	Description
<code>CMD:ERASE</code>	Executes a chip erase of the target
<code>CMD:SEND_UART=</code>	Sends a string of characters to the CDC UART. See <a href="#">CDC Override Mode</a> .
<code>CMD:RESET</code>	Resets the target device by entering Programming mode and then exiting Programming mode immediately thereafter. Exact timing can vary according to the programming interface of the target device (debugger firmware v1.16 or latest).

**Info:** The commands listed above are triggered by the content being sent to the mass storage emulated disk, and no feedback is provided in the case of either success or failure.

### 4.1.4 Data Gateway Interface (DGI)

Data Gateway Interface (DGI) is a USB interface for transporting raw and time-stamped data between on-board debuggers and host computer-based visualization tools. [MPLAB Data Visualizer](#) is used on the host computer to display debug GPIO data. It is available as a plug-in for MPLAB X IDE or as a stand-alone application that can be used in parallel with MPLAB X IDE.

Although DGI encompasses several physical data interfaces, the SAM-IoT Wx development board implementation includes logic analyzer channels: One debug GPIO channel (also known as DGI GPIO).

#### 4.1.4.1 Debug GPIO

Debug GPIO channels are timestamped digital signal lines connecting the target application to a host computer visualization application. They are typically used to plot the occurrence of low-frequency events on a time-axis. For example, when certain application state transitions occur.

The following figure shows the monitoring of the digital state of a mechanical switch connected to a debug GPIO in MPLAB Data Visualizer.

**Figure 4-2. Monitoring Debug GPIO with MPLAB Data Visualizer**

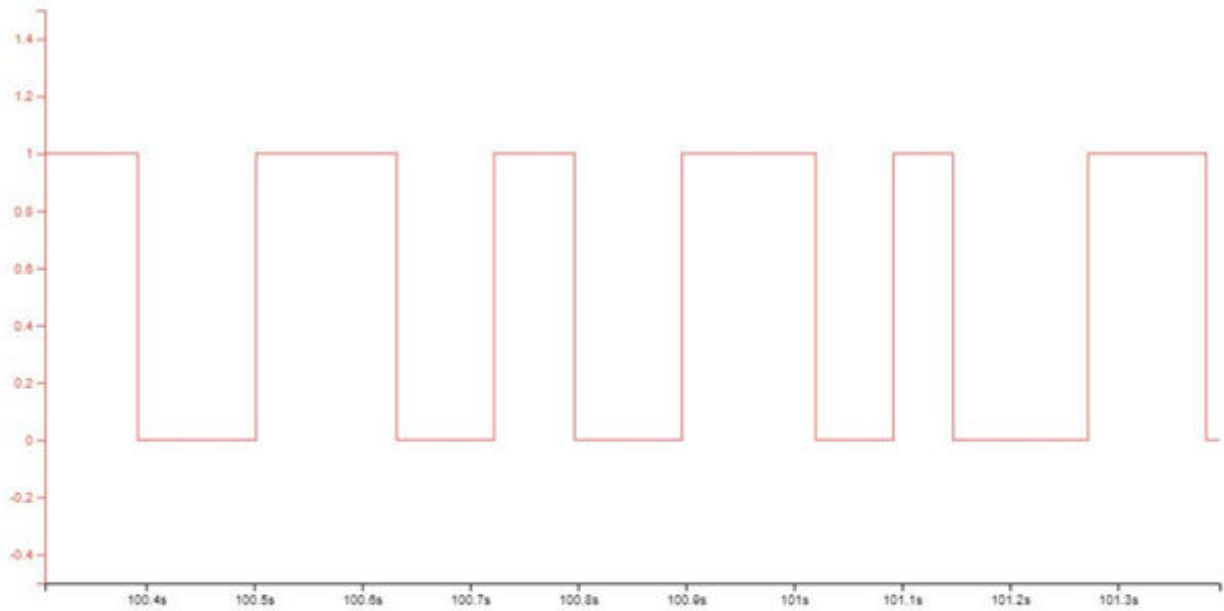

Debug GPIO channels are timestamped, hence the resolution of DGI GPIO events is determined by the resolution of the DGI timestamp module.



**Important:** Although bursts of higher-frequency signals can be captured, the useful frequency range of signals for which debug GPIO can be used is up to about 2 kHz. Attempting to capture signals above this frequency will result in data saturation and overflow, which may cause the DGI session to be aborted.

#### 4.1.4.2 Timestamping

DGI sources are timestamped as they are captured by the debugger. The timestamp counter implemented in the Curiosity Nano debugger increments at 2 MHz frequency, providing a timestamp resolution of a half microsecond.

## 4.2 On-Board Debugger Connections

The following table provides the connections between the target and the debugger section. All connections between the target and the debugger are tri-stated as long as the debugger is not actively using the interface. Because there is little contamination of the signals, the pins can be configured to anything the user wants.

For additional information on how to use the capabilities of the on-board debugger, see [On-Board Debugger Overview](#).

**Table 4-3. On-Board Debugger Connections**

Debugger Pin	ATSAMD21G18 Pin	Function	Shared Functionality
CDC TX	PB02	SERCOM 5	-
CDC RX	PB03	SERCOM 5	-
DBG0	PA31	SWDIO	-
DBG1	PA30	SWCLK	-
DBG2	PA28	DGI GPIO0	-
DBG3	RESETN	RESET	-

## 4.3 Power

### 4.3.1 Power Source

The development board can be powered through the USB port or by a Li-Ion/Li-Polymer battery. The board contains one buck converter for generating 3.3V for the debugger, target, and peripherals.

The maximum available current from the USB is limited to 500 mA. The current will be shared between charging the battery (if connected) and the target application section.

**Figure 4-3. Power Supply Block Diagram**

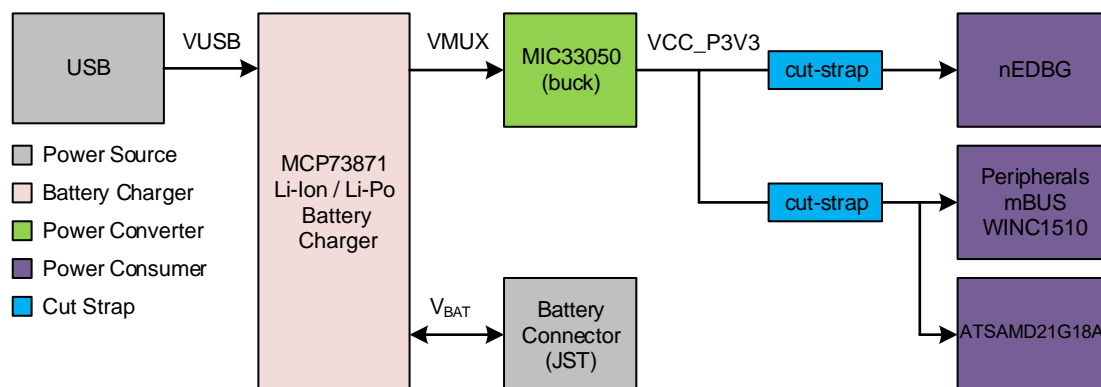

### 4.3.2 Battery Charger

The SAM-IoT Wx development board features an MCP73871 Li-Ion/Li-Polymer charger and JST battery connector on board. The charger is configured to limit the charge current to 100 mA to prevent the overcharging of small capacity batteries. Minimum recommended battery capacity is 400 mAh. The table below provides the charger status of LEDs.



The MCP73871 has a battery charge voltage of 4.2V. Make sure the battery has the same charge voltage.

**Table 4-4. Charger Status LEDs**

LEDs	Function
Red (charging)	The battery is being charged by the USB

.....continued	
LEDs	Function
Red (discharging)	The battery voltage is low. Triggers if the voltage is under 3.1V.
Green	Charge complete
Red and Green	Timer Fault. The six-hour charge cycle has timed out before the complete charge.

### 4.3.3 Hardware Modifications

On the bottom side of the SAM-IoT Wx development board there are two cut-straps, as shown in the following figure, which are intended for current measurements. Do not leave these unconnected as the microcontrollers might get powered through the I/O's.

**Figure 4-4. VCC Cut-Straps**



The 5V supply to the mikroBUS socket is connected by default. To remove 5V from the socket, desolder the 0-ohm resistor (0402) below the 5V text, as shown in the following figure.

**Figure 4-5. mikroBUS™ 5V Footprint**



## 4.4 Components

### 4.4.1 ATSAM D21G18A

Microchip SAM D21 is a series of low-power microcontrollers using the 32-bit Arm Cortex-M0+ processor and ranging from 32-pins to 64-pins with up to 256-KB Flash and 32-KB SRAM. The SAM D21 operates at a maximum frequency of 48 MHz and reaches 2.46 CoreMark/MHz. They are designed for simple and intuitive migration with identical peripheral modules, hex compatible code, identical linear address map, and pin compatible migration paths between all devices in the product series. All devices include intelligent and flexible peripherals, such as an Event System for inter-peripheral signaling, and support for capacitive touch button, slider, and wheel user interfaces.

### 4.4.2 mikroBUS™ Socket

The SAM-IoT Wx development board features a mikroBUS socket for expanding the functionality of the development board using MikroElektronika Click Boards and other mikroBUS add-on boards. The socket is populated with two 1x8 2.54 mm pitch female headers and is ready to mount add-on boards.

**Table 4-5. mikroBUS™ Socket Pinout**

mikroBUS™ Socket Pin	ATSAMD21G18A Pin	Function	Shared Functionality
AN	PA02	ADC AIN0	-
RST	PA03	GPIO	-
CS	PA06	SERCOM 0	-
SCK	PA05	SERCOM 0	-
MISO	PA07	SERCOM 0	-
MOSI	PA04	SERCOM 0	-
+3.3V		VCC_TARGET (3.3V)	
GND		Ground	
PWM	PA10	TCC0/1	-
INT	PA24	GPIO	-
RX	PA09	SERCOM 2 UART RX	-
TX	PA08	SERCOM 2 UART TX	-
SCL	PA17	SERCOM 1	-
SDA	PA16	SERCOM 1	-
+5V		VCC_MUX <sup>(1)</sup> , MCP73871 output	
GND		Ground	

**Note:**

1. A 0-ohm resistor has been soldered to connect the VCC\_MUX pin to the mikroBUS socket. If an add-on module cannot handle 5V on this pin, the 0-ohm resistor must be removed. For additional information, see [Hardware Modifications](#).

### 4.4.3 ATWINC1510 Wi-Fi Module

Microchip's ATWINC1510 is a low-power consumption IEEE® 802.11 b/g/n IoT module, specifically optimized for low-power IoT applications. The module integrates Power Amplifier (PA), Low-Noise Amplifier (LNA), switch, power management, and a printed antenna or a micro co-ax (U.FL) connector for an external antenna resulting in a small form factor (21.7x14.7x2.1 mm) design. It is interoperable with various vendors' 802.11 b/g/n access points. This module provides SPI ports to interface with a host controller.

The ATWINC1510 provides internal Flash memory and multiple peripheral interfaces, including UART and SPI. The only external clock source needed for ATWINC1510 is the built-in, high-speed crystal, or oscillator (26 MHz). The ATWINC1510 is available in a QFN package or as a certified module.

The communication interface between the ATSAMd21G18A and ATWINC1510 Wi-Fi module is the SPI, together with some enabled signals and interrupts. The rest of the connections are left unconnected.

**Table 4-6. ATWINC1510 Connections**

ATWINC1510 Pin	ATSAMD21G18A Pin	Function	Shared Functionality
4 RESET_N	PB10	GPIO	-
9 GND		Ground	
10 SPI_CFG		Pulled-up to VCC_WINC	
11 WAKE	PA19	GPIO	-
12 GND		Ground	
13 IRQN	PA18	EIC EXT INT 2	-
15 SPI_MOSI	PA12	SERCOM 4	-
16 SPI_SSN	PA14	SERCOM 4	-
17 SPI_MISO	PA15	SERCOM 4	-
18 SPI_SCK	PA13	SERCOM 4	-
20 VBAT		VCC_WINC (3.3V)	
22 CHIP_EN	PB11	GPIO	-
23 VDDIO		VCC_WINC (3.3V)	-
28 GND		Ground	-
29 PADDLE		Ground	-

#### 4.4.4 ATECC608A

The ATECC608A is a secure element from the Microchip CryptoAuthentication portfolio with advanced Elliptic Curve Cryptography (ECC) capabilities. With ECDH and ECDSA being built right in, this device is ideal for the rapidly growing Internet of Things (IoT) market by easily supplying the full range of security, such as confidentiality, data integrity, and authentication to systems with MCU or MPUs running encryption/decryption algorithms. Similar to all Microchip CryptoAuthentication products, the new ATECC608A employs ultra-secure, hardware-based cryptographic key storage and cryptographic countermeasures that eliminate any potential backdoors linked to software weaknesses.

The ATECC608A CryptoAuthentication device on the SAM-IoT Wx development board is used to authenticate the hardware with cloud service providers to uniquely identify every board.

**Note:** 7-bit I<sup>2</sup>C address: 0x58.

**Table 4-7. ATECC608A Connections**

ATECC608A Pin	ATSAMD21G18A Pin	Function	Shared Functionality
SDA	PA22	SERCOM 3	MCP9808
SCL	PA23	SERCOM 3	MCP9808

#### 4.4.5 Temperature Sensor

The MCP9808 digital temperature sensor converts temperatures between -20°C and +100°C to a digital word with ±0.25°C/±0.5°C (typical/maximum) accuracy.

Additional features:



- Accuracy:
  - $\pm 0.25^{\circ}\text{C}$  (typical) from  $-40^{\circ}\text{C}$  to  $+125^{\circ}\text{C}$
  - $\pm 0.5^{\circ}\text{C}$  (maximum) from  $-20^{\circ}\text{C}$  to  $+100^{\circ}\text{C}$
- User Selectable Measurement Resolution:
  - $0.5^{\circ}\text{C}$ ,  $0.25^{\circ}\text{C}$ ,  $0.125^{\circ}\text{C}$ ,  $0.0625^{\circ}\text{C}$
- User Programmable Temperature Limits:
  - Temperature Window Limit
  - Critical Temperature Limit
- User Programmable Temperature Alert Output
- Operating Voltage Range:
  - 2.7V to 5.5V
- Operating Current:
  - 200  $\mu\text{A}$  (typical)
- Shutdown Current:
  - 0.1  $\mu\text{A}$  (typical)

The MCP9808 temperature sensor is connected to the ATSAMD21G18A through the I<sup>2</sup>C and a GPIO for user-configurable alert output.

**Note:** 7-bit I<sup>2</sup>C address: 0x18.

**Table 4-8. MCP9808**

MCP9808 Pin	ATSAMD21G18A Pin	Function	Shared Functionality
SDA	PA22	SERCOM 3	ATECC608A
SCL	PA23	SERCOM 3	ATECC608A
Alert	PA27	EIC EXT INT15	-

#### 4.4.6 Light Sensor

A TMT6000X01 light sensor is mounted on the SAM-IoT Wx development board for measuring the light intensity. The sensor is a current source that will induce a voltage across the series resistor, which in turn can be measured by the ATSAMD21G18A ADC. The current is exponentially relative to illuminance, from about 10  $\mu\text{A}$ @20lx to 50  $\mu\text{A}$ @100lx. The series resistor has a value of 10 k $\Omega$ .

ATSAMD21G18A Pin	Function	Shared Functionality
PB08	ADC AIN2	-

#### 4.4.7 LED

Four LEDs are available on the SAM-IoT Wx development board that can be controlled with PWM or GPIO. The LEDs can be activated by driving the connected I/O line to GND.

**Table 4-9. LED Connections**

ATSAMD21G18A Pin	Function	Description
PA25	GPIO	Red LED
PA11	GPIO	Yellow LED
PA20	GPIO	Green LED
PA21	GPIO	Blue LED

#### 4.4.8 Mechanical Buttons

The SAM-IoT Wx development board contains two mechanical buttons. These are generic user-configurable buttons. When a button is pressed, it will drive the connected I/O line to ground (GND).

**Info:** There are no pull-up resistors connected to the generic user buttons. Remember to enable the internal pull-up in the ATSAM21G18A to use the buttons.

**Table 4-10. Mechanical Button**

ATSAMD21G18A Pin	Description	Shared Functionality
PA00	User switch 0 (SW0)	-
PA01	User switch 1 (SW1)	-

## **5. Regulatory Approval**

### **5.1 United States**

Contains Transmitter Module FCC ID: 2ADHKATWINC1510.

This equipment has been tested and found to comply with the limits for a Class B digital device, pursuant to part 15 of the FCC Rules. These limits are designed to provide reasonable protection against harmful interference in a residential installation. This equipment generates, uses, and can radiate radio frequency energy, and if not installed and used in accordance with the instructions, may cause harmful interference to radio communications. However, there is no guarantee that interference will not occur in a particular installation. If this equipment does cause harmful interference to radio or television reception, which can be determined by turning the equipment off and on, the user is encouraged to try to correct the interference by one or more of the following measures:

- Reorient or relocate the receiving antenna
- Increase the separation between the equipment and receiver
- Connect the equipment into an outlet on a circuit different from that to which the receiver is connected
- Consult the dealer or an experienced radio/TV technician for help

### **5.2 Canada**

Contains IC: 20266-ATWINC1510.

This device complies with Industry Canada's license-exempt RSS standard(s). Operation is subject to the following two conditions:

1. This device may not cause interference, and
2. This device must accept any interference, including interference that may cause undesired operation of the device.

Le présent appareil est conforme aux CNR d'Industrie Canada applicables aux appareils radio exempts de licence.

L'exploitation est autorisée aux deux conditions suivantes:

1. l'appareil ne doit pas produire de brouillage, et
2. l'utilisateur de l'appareil doit accepter tout brouillage radioélectrique subi, même si le brouillage est susceptible d'en compromettre le fonctionnement.

Guidelines on Transmitter Antenna for License Exempt Radio Apparatus:

Under Industry Canada regulations, this radio transmitter may only operate using an antenna of a type and maximum (or lesser) gain approved for the transmitter by Industry Canada. To reduce potential radio interference to other users, the antenna type and its gain should be so chosen that the equivalent isotropically radiated power (e.i.r.p.) is not more than that necessary for successful communication.

Conformément à la réglementation d'Industrie Canada, le présent émetteur radio peut fonctionner avec une antenne d'un type et d'un gain maximal (ou inférieur) approuvé pour l'émetteur par Industrie Canada. Dans le but de réduire les risques de brouillage radioélectrique à l'intention des autres utilisateurs, il faut choisir le type d'antenne et son gain de sorte que la puissance isotrope rayonnée équivalente (p.i.r.e.) ne dépasse pas l'intensité nécessaire à l'établissement d'une communication satisfaisante.

### **5.3 Taiwan**

Contains module: CCAN18LP0320T0.

注意！

依據 低功率電波輻射性電機管理辦法

第十二條 經型式認證合格之低功率射頻電機，非經許可，公司、商號或使用者均不得擅自變更頻率、加大功率或變更原設計之特性及功能。

第十四條 低功率射頻電機之使用不得影響飛航安全及干擾合法通信；經發現有干擾現象時，應立即停用，並改善至無干擾時方得繼續使用。

前項合法通信，指依電信規定作業之無線電信。

低功率射頻電機須忍受合法通信或工業、科學及醫療用電波輻射性電機設備之干擾。

## 5.4 List of Antenna Types

ATWINC1510-MR210 does not allow the use of external antennas and is tested with the PCB antenna on the module.

## 6. Hardware Revision History

This document is written to provide information about the latest available revision of the board.

### 6.1 Identifying Product ID and Revision

The revision and product identifier of the SAM-IoT Wx development board can be found in two ways: Either by utilizing the MPLAB X IDE Kit Window or by looking at the sticker on the bottom side of the PCB.

By connecting a SAM-IoT Wx development board to a computer with MPLAB X IDE running, the Kit Window will pop up. The first six digits of the serial number, which is listed under kit information, contain the product identifier and revision.



**Tip:** The Kit Window can be opened in MPLABX IDE, from the menu bar *Window > Kit Window*.

The same information can be found on the sticker on the bottom side of the PCB. Most boards will have the identifier and revision printed in plain text as A09-nnnn\rr, where “nnnn” is the identifier, and “rr” is the revision. Boards with limited space have a sticker with only a data matrix code, containing the product identifier, revision, and serial number.

The serial number string has the following format:

"nnnnrrssssssssss"

n = product identifier

r = revision

s = serial number

The product identifier for SAM-IoT Wx development board is A08-3035.

## 7. Appendix

### 7.1 Schematics

# SAM-IoT Wx Schematics

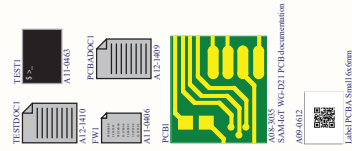
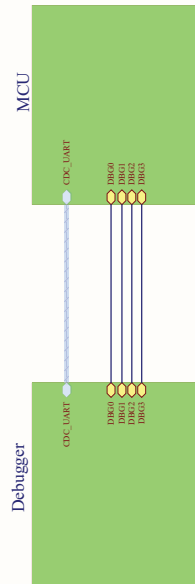

HISTORY

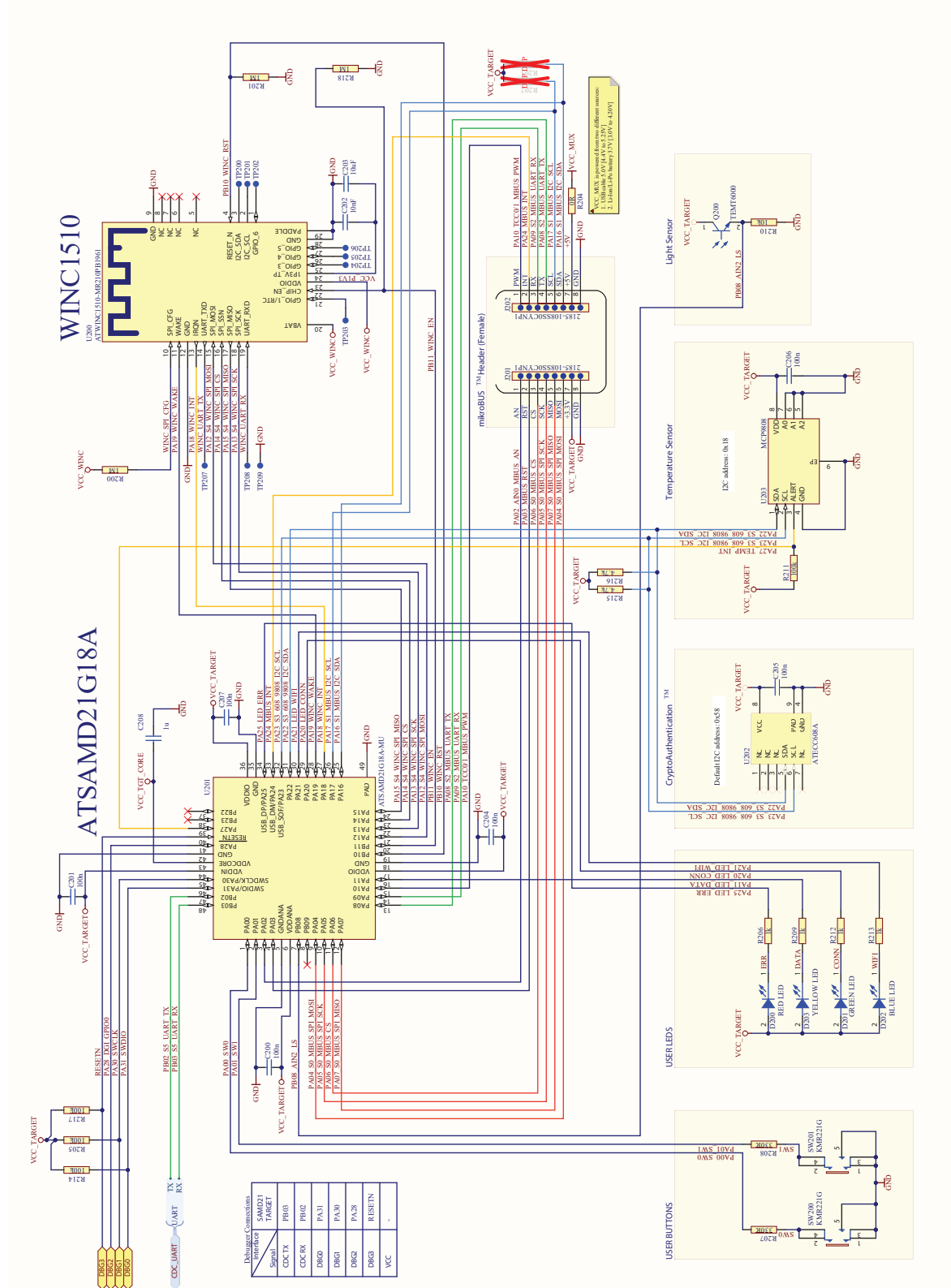

POWER SUPPLY AND BATTERY CHARGER

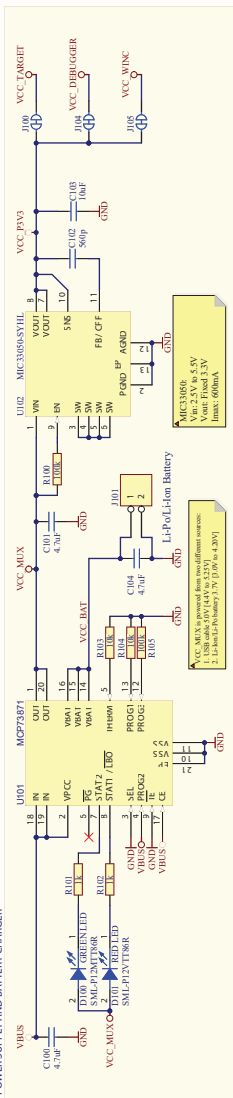

DEBUGGER TESTPOINT

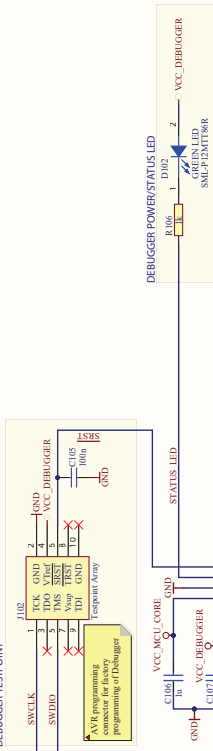

Debugger	ICSP	UPDR	SWD
Target	Target	Target	Target
CKX TX	UART RX	UART RX	UART RX
CKX RX	UART TX	UART TX	UART TX
DBG0	DAT	UPDR	SWDIO
DBG1	CLK	GPIO	SWCLK
DBG2	GPIO	GPIO	SWO/STROBE
DBG3	MCUR	RESET	RESET
VCC			

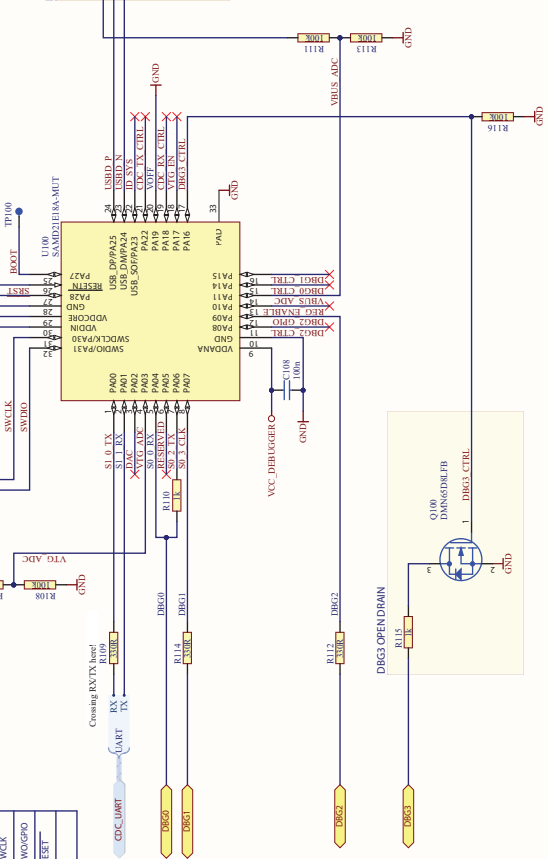



## 7.2 Assembly Drawing

Figure 7-1. SAM-IoT Wx Development Board Assembly Drawing Top

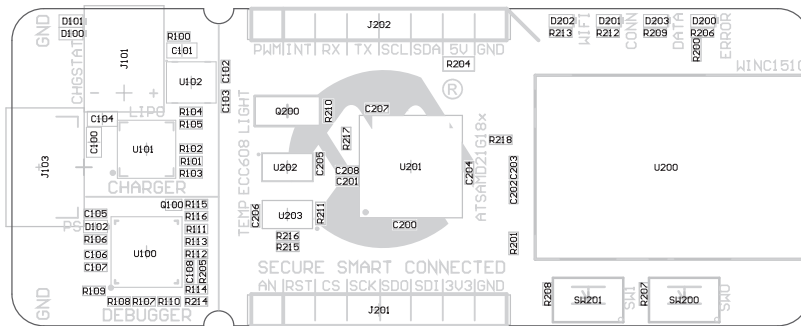
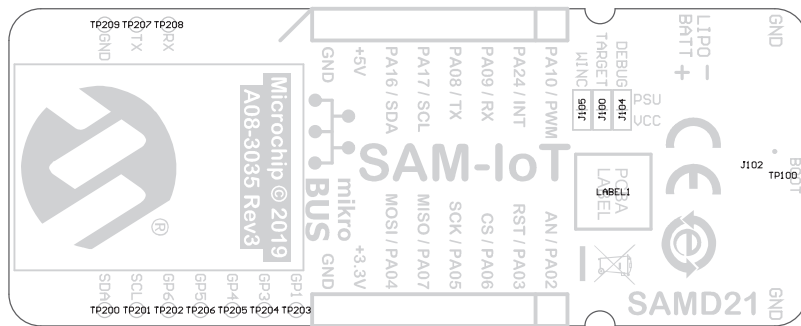

Figure 7-2. SAM-IoT Wx Development Board Assembly Drawing Bottom



## 7.3 Mechanical Drawings

The following figures show the board's mechanical drawing and connector placement.

Figure 7-3. Mechanical Dimensions

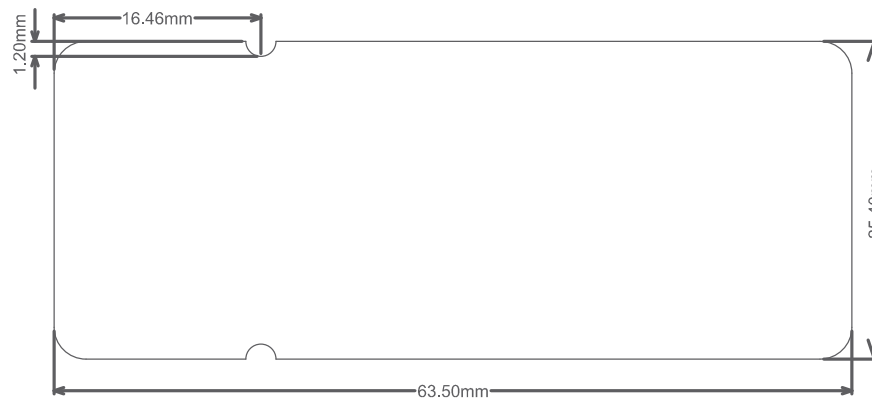
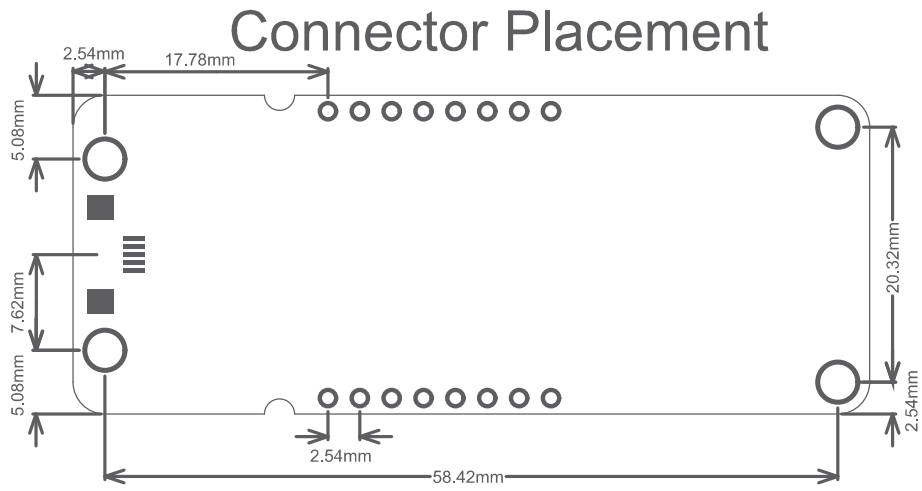

Figure 7-4. Connector Placement



### 7.4 Bill of Materials

Qty	Designator	Description	Value	Manufacturer	MPN
1	C102	Ceramic capacitor, SMD 0402, X7R, 50V, +/-10%	560p		
2	C103, C203	Ceramic capacitor, SMD 0402, X5R, 6.3V, 20%	10uF	Murata	GRM155R60J106ME15
9	C105, C107, C108, C200, C201, C204, C205, C206, C207	Ceramic capacitor, SMD 0402, X7R, 16V, +/-10%	100n	Kemet	C0402C104K4RACTU
2	C106, C208	Ceramic capacitor, SMD 0402, X5R, 6.3V, +/-10%	1u	Kemet	C0402C105K9PAC
1	C202	Ceramic capacitor, SMD 0402, X7R, 25V, 10%	10nF	Murata	GRM155R71E103KA01D
3	D100, D102, D201	LED, SMD 0402, Green, Wave length=569nm	GREEN LED	ROHM	SML-P12MTT86R
2	D101, D200	LED, SMD 0402, Red, Wave length=630nm	RED LED	ROHM	SML-P12VTT86R
1	D202	LED, SMD 0402, Blue, Wave length=470nm	BLUE LED	ROHM	SMLP13BC8TT86
1	D203	LED, SMD 0402, Yellow, Wave length=586nm	YELLOW LED	ROHM	SML-P12YTT86R
1	J101	Pin Header 1x2, 2mm THM, RA	S2B-PH-K-S	J.S.T. Mfg.	S2B-PH-K-S
2	J201, J202	1x8 receptacle pin header, 2.54mm pitch THM, PIP	2185-108SS0CYNP1	WCON	2185-108SS0CYNP1
1	Q100	N-ch MOSFET, DFN1006-3 (SOT883), 60V, 330mA	DMN65D8LFB	Diodes Inc	DMN65D8LFB-7
1	Q200	light sensor	TEMT6000	Vishay	TEMT6000X01
3	R103, R104, R210	Thick film resistor, SMD 0402, 1/16W, 1%	10k	Yageo	RC0402FR-0710KL
5	R109, R112, R114, R207, R208	Thick film resistor, SMD 0402, 1/16W, 1%	330R	Yageo	RC0402FR-07330RL
3	R200, R201, R218	Thick film resistor, SMD 0402, 1/16W, 1%	1M	ASJ	CR10-1004-FK
1	R204	RES 0.0 OHM 1/16W 0402 SMD	0R	(n/a)	RMCF0402ZT0R00
3	R205, R214, R217	Thick film resistor, SMD 0402, 1/16W, 1%	100k	ASJ	CR10-1003-FK
2	R215, R216	Thick film resistor, SMD 0402, 1/16W, 1%	4.7k	Yageo	RC0402FR-074K7L
2	SW200, SW201	Microminiature Tact Switch for SMT	KMR221G	ITT Corp.	KMR221G
1	U100	Atmel 32-bit RISC MCU 32pin	SAMD21E18A-MUT	Microchip	ATSAMD21E18A-MUT
1	U101	Li-Ion/Li-Polymer Battery Charge Controller	MCP73871	Microchip	MCP73871T-2CCI/ML
1	U102	3.3V Fixed, 4MHz, 600mA, Buck regulator	MIC33050-SYHL	Microchip	MIC33050-SYHL-TR
1	U200	IEEE 802.11 b/g/n module, 8Mbit Flash Memory	ATWINC1510-MR210PB1961	Microchip	ATWINC1510-MR210PB1961
1	U201	MCU 32-BIT 32kB 256kB 48MHz QFN48	ATSAMD21G18A-MU	Microchip	ATSAMD21G18A-MU
1	U202	ATECC608A with an I <sup>2</sup> C Interface and a 8 Pin UDFN	ATECC608A I2C	Microchip	ATECC608A-MAH1H-S
1	U203	±0.5C Digital Temperature Sensor, I <sup>2</sup> C/SMBus	MCP9808	Microchip	MCP9808T-E/MC

## **8. Revision History**

### **Revision A - July 2020**

This is the initial released version of this document.

## The Microchip Website

---

Microchip provides online support via our website at [www.microchip.com/](http://www.microchip.com/). This website is used to make files and information easily available to customers. Some of the content available includes:

- **Product Support** – Data sheets and errata, application notes and sample programs, design resources, user's guides and hardware support documents, latest software releases and archived software
- **General Technical Support** – Frequently Asked Questions (FAQs), technical support requests, online discussion groups, Microchip design partner program member listing
- **Business of Microchip** – Product selector and ordering guides, latest Microchip press releases, listing of seminars and events, listings of Microchip sales offices, distributors and factory representatives

## Product Change Notification Service

---

Microchip's product change notification service helps keep customers current on Microchip products. Subscribers will receive email notification whenever there are changes, updates, revisions or errata related to a specified product family or development tool of interest.

To register, go to [www.microchip.com/pcn](http://www.microchip.com/pcn) and follow the registration instructions.

## Customer Support

---

Users of Microchip products can receive assistance through several channels:

- Distributor or Representative
- Local Sales Office
- Embedded Solutions Engineer (ESE)
- Technical Support

Customers should contact their distributor, representative or ESE for support. Local sales offices are also available to help customers. A listing of sales offices and locations is included in this document.

Technical support is available through the website at: [www.microchip.com/support](http://www.microchip.com/support)

## Microchip Devices Code Protection Feature

---

Note the following details of the code protection feature on Microchip devices:

- Microchip products meet the specification contained in their particular Microchip Data Sheet.
- Microchip believes that its family of products is one of the most secure families of its kind on the market today, when used in the intended manner and under normal conditions.
- There are dishonest and possibly illegal methods used to breach the code protection feature. All of these methods, to our knowledge, require using the Microchip products in a manner outside the operating specifications contained in Microchip's Data Sheets. Most likely, the person doing so is engaged in theft of intellectual property.
- Microchip is willing to work with the customer who is concerned about the integrity of their code.
- Neither Microchip nor any other semiconductor manufacturer can guarantee the security of their code. Code protection does not mean that we are guaranteeing the product as "unbreakable."

Code protection is constantly evolving. We at Microchip are committed to continuously improving the code protection features of our products. Attempts to break Microchip's code protection feature may be a violation of the Digital Millennium Copyright Act. If such acts allow unauthorized access to your software or other copyrighted work, you may have a right to sue for relief under that Act.

## Legal Notice

---

Information contained in this publication regarding device applications and the like is provided only for your convenience and may be superseded by updates. It is your responsibility to ensure that your application meets with

your specifications. MICROCHIP MAKES NO REPRESENTATIONS OR WARRANTIES OF ANY KIND WHETHER EXPRESS OR IMPLIED, WRITTEN OR ORAL, STATUTORY OR OTHERWISE, RELATED TO THE INFORMATION, INCLUDING BUT NOT LIMITED TO ITS CONDITION, QUALITY, PERFORMANCE, MERCHANTABILITY OR FITNESS FOR PURPOSE. Microchip disclaims all liability arising from this information and its use. Use of Microchip devices in life support and/or safety applications is entirely at the buyer's risk, and the buyer agrees to defend, indemnify and hold harmless Microchip from any and all damages, claims, suits, or expenses resulting from such use. No licenses are conveyed, implicitly or otherwise, under any Microchip intellectual property rights unless otherwise stated.

## Trademarks

---

The Microchip name and logo, the Microchip logo, Adaptec, AnyRate, AVR, AVR logo, AVR Freaks, BesTime, BitCloud, chipKIT, chipKIT logo, CryptoMemory, CryptoRF, dsPIC, FlashFlex, flexPWR, HELDO, IGLOO, JukeBlox, KeeLoq, Kleer, LANCheck, LinkMD, maXStylus, maXTouch, MediaLB, megaAVR, Microsemi, Microsemi logo, MOST, MOST logo, MPLAB, OptoLyzer, PackeTime, PIC, picoPower, PICSTART, PIC32 logo, PolarFire, Prochip Designer, QTouch, SAM-BA, SenGenuity, SpyNIC, SST, SST Logo, SuperFlash, Symmetricom, SyncServer, Tachyon, TempTrackr, TimeSource, tinyAVR, UNI/O, Vectron, and XMEGA are registered trademarks of Microchip Technology Incorporated in the U.S.A. and other countries.

APT, ClockWorks, The Embedded Control Solutions Company, EtherSynch, FlashTec, Hyper Speed Control, HyperLight Load, IntelliMOS, Libero, motorBench, mTouch, Powermite 3, Precision Edge, ProASIC, ProASIC Plus, ProASIC Plus logo, Quiet-Wire, SmartFusion, SyncWorld, Temux, TimeCesium, TimeHub, TimePictra, TimeProvider, Vite, WinPath, and ZL are registered trademarks of Microchip Technology Incorporated in the U.S.A.

Adjacent Key Suppression, AKS, Analog-for-the-Digital Age, Any Capacitor, AnyIn, AnyOut, BlueSky, BodyCom, CodeGuard, CryptoAuthentication, CryptoAutomotive, CryptoCompanion, CryptoController, dsPICDEM, dsPICDEM.net, Dynamic Average Matching, DAM, ECAN, EtherGREEN, In-Circuit Serial Programming, ICSP, INICnet, Inter-Chip Connectivity, JitterBlocker, KleerNet, KleerNet logo, memBrain, Mindi, MiWi, MPASM, MPF, MPLAB Certified logo, MPLIB, MPLINK, MultiTRAK, NetDetach, Omniscient Code Generation, PICDEM, PICDEM.net, PICkit, PICtail, PowerSmart, PureSilicon, QMatrix, REAL ICE, Ripple Blocker, SAM-ICE, Serial Quad I/O, SMART-I.S., SQI, SuperSwitcher, SuperSwitcher II, Total Endurance, TSHARC, USBCheck, VariSense, ViewSpan, WiperLock, Wireless DNA, and ZENA are trademarks of Microchip Technology Incorporated in the U.S.A. and other countries.

SQTP is a service mark of Microchip Technology Incorporated in the U.S.A.

The Adaptec logo, Frequency on Demand, Silicon Storage Technology, and Symmcom are registered trademarks of Microchip Technology Inc. in other countries.

GestIC is a registered trademark of Microchip Technology Germany II GmbH & Co. KG, a subsidiary of Microchip Technology Inc., in other countries.

All other trademarks mentioned herein are property of their respective companies.

© 2020, Microchip Technology Incorporated, Printed in the U.S.A., All Rights Reserved.

ISBN: 978-1-5224-6496-9

## Quality Management System

---

For information regarding Microchip's Quality Management Systems, please visit [www.microchip.com/quality](http://www.microchip.com/quality).

## Worldwide Sales and Service

AMERICAS	ASIA/PACIFIC	ASIA/PACIFIC	EUROPE
<p><b>Corporate Office</b> 2355 West Chandler Blvd. Chandler, AZ 85224-6199 Tel: 480-792-7200 Tel: 480-792-7277 Technical Support: <a href="http://www.microchip.com/support">www.microchip.com/support</a> Web Address: <a href="http://www.microchip.com">www.microchip.com</a></p> <p><b>Atlanta</b> Duluth, GA Tel: 678-957-9614 Fax: 678-957-1455</p> <p><b>Austin, TX</b> Tel: 512-257-3370</p> <p><b>Boston</b> Westborough, MA Tel: 774-760-0087 Fax: 774-760-0088</p> <p><b>Chicago</b> Itasca, IL Tel: 630-285-0071 Fax: 630-285-0075</p> <p><b>Dallas</b> Addison, TX Tel: 972-818-7423 Fax: 972-818-2924</p> <p><b>Detroit</b> Novi, MI Tel: 248-848-4000</p> <p><b>Houston, TX</b> Tel: 281-894-5983</p> <p><b>Indianapolis</b> Noblesville, IN Tel: 317-773-8323 Fax: 317-773-5453 Tel: 317-536-2380</p> <p><b>Los Angeles</b> Mission Viejo, CA Tel: 949-462-9523 Fax: 949-462-9608 Tel: 951-273-7800</p> <p><b>Raleigh, NC</b> Tel: 919-844-7510</p> <p><b>New York, NY</b> Tel: 631-435-6000</p> <p><b>San Jose, CA</b> Tel: 408-735-9110 Tel: 408-436-4270</p> <p><b>Canada - Toronto</b> Tel: 905-695-1980 Fax: 905-695-2078</p>	<p><b>Australia - Sydney</b> Tel: 61-2-9868-6733</p> <p><b>China - Beijing</b> Tel: 86-10-8569-7000</p> <p><b>China - Chengdu</b> Tel: 86-28-8665-5511</p> <p><b>China - Chongqing</b> Tel: 86-23-8980-9588</p> <p><b>China - Dongguan</b> Tel: 86-769-8702-9880</p> <p><b>China - Guangzhou</b> Tel: 86-20-8755-8029</p> <p><b>China - Hangzhou</b> Tel: 86-571-8792-8115</p> <p><b>China - Hong Kong SAR</b> Tel: 852-2943-5100</p> <p><b>China - Nanjing</b> Tel: 86-25-8473-2460</p> <p><b>China - Qingdao</b> Tel: 86-532-8502-7355</p> <p><b>China - Shanghai</b> Tel: 86-21-3326-8000</p> <p><b>China - Shenyang</b> Tel: 86-24-2334-2829</p> <p><b>China - Shenzhen</b> Tel: 86-755-8864-2200</p> <p><b>China - Suzhou</b> Tel: 86-186-6233-1526</p> <p><b>China - Wuhan</b> Tel: 86-27-5980-5300</p> <p><b>China - Xian</b> Tel: 86-29-8833-7252</p> <p><b>China - Xiamen</b> Tel: 86-592-2388138</p> <p><b>China - Zhuhai</b> Tel: 86-756-3210040</p>	<p><b>India - Bangalore</b> Tel: 91-80-3090-4444</p> <p><b>India - New Delhi</b> Tel: 91-11-4160-8631</p> <p><b>India - Pune</b> Tel: 91-20-4121-0141</p> <p><b>Japan - Osaka</b> Tel: 81-6-6152-7160</p> <p><b>Japan - Tokyo</b> Tel: 81-3-6880-3770</p> <p><b>Korea - Daegu</b> Tel: 82-53-744-4301</p> <p><b>Korea - Seoul</b> Tel: 82-2-554-7200</p> <p><b>Malaysia - Kuala Lumpur</b> Tel: 60-3-7651-7906</p> <p><b>Malaysia - Penang</b> Tel: 60-4-227-8870</p> <p><b>Philippines - Manila</b> Tel: 63-2-634-9065</p> <p><b>Singapore</b> Tel: 65-6334-8870</p> <p><b>Taiwan - Hsin Chu</b> Tel: 886-3-577-8366</p> <p><b>Taiwan - Kaohsiung</b> Tel: 886-7-213-7830</p> <p><b>Taiwan - Taipei</b> Tel: 886-2-2508-8600</p> <p><b>Thailand - Bangkok</b> Tel: 66-2-694-1351</p> <p><b>Vietnam - Ho Chi Minh</b> Tel: 84-28-5448-2100</p>	<p><b>Austria - Wels</b> Tel: 43-7242-2244-39 Fax: 43-7242-2244-393</p> <p><b>Denmark - Copenhagen</b> Tel: 45-4485-5910 Fax: 45-4485-2829</p> <p><b>Finland - Espoo</b> Tel: 358-9-4520-820</p> <p><b>France - Paris</b> Tel: 33-1-69-53-63-20 Fax: 33-1-69-30-90-79</p> <p><b>Germany - Garching</b> Tel: 49-8931-9700</p> <p><b>Germany - Haan</b> Tel: 49-2129-3766400</p> <p><b>Germany - Heilbronn</b> Tel: 49-7131-72400</p> <p><b>Germany - Karlsruhe</b> Tel: 49-721-625370</p> <p><b>Germany - Munich</b> Tel: 49-89-627-144-0 Fax: 49-89-627-144-44</p> <p><b>Germany - Rosenheim</b> Tel: 49-8031-354-560</p> <p><b>Israel - Ra'anana</b> Tel: 972-9-744-7705</p> <p><b>Italy - Milan</b> Tel: 39-0331-742611 Fax: 39-0331-466781</p> <p><b>Italy - Padova</b> Tel: 39-049-7625286</p> <p><b>Netherlands - Drunen</b> Tel: 31-416-690399 Fax: 31-416-690340</p> <p><b>Norway - Trondheim</b> Tel: 47-72884388</p> <p><b>Poland - Warsaw</b> Tel: 48-22-3325737</p> <p><b>Romania - Bucharest</b> Tel: 40-21-407-87-50</p> <p><b>Spain - Madrid</b> Tel: 34-91-708-08-90 Fax: 34-91-708-08-91</p> <p><b>Sweden - Gothenberg</b> Tel: 46-31-704-60-40</p> <p><b>Sweden - Stockholm</b> Tel: 46-8-5090-4654</p> <p><b>UK - Wokingham</b> Tel: 44-118-921-5800 Fax: 44-118-921-5820</p>