

HI1206T500R-10

PHYSICAL DIMENSIONS:

A	3.20 [.126]	+ 0.20 [.008]
B	1.60 [.063]	+ 0.20 [.008]
C	1.10 [.043]	+ 0.20 [.008]
D	0.51 [.020]	+ 0.25 [.010]

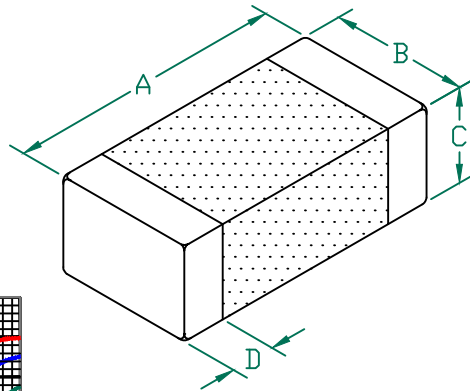

ELECTRICAL CHARACTERISTICS:

	Z @ 100MHz (Ω)	DCR (Ω)	Rated Current
Nominal	50		
Minimum	38		
Maximum	63	0.010	6000 mA

NOTES: UNLESS OTHERWISE SPECIFIED

1. TAPED AND REELED per CURRENT EIA SPECIFICATIONS 7" REELS, 3000 PCS/REEL.
2. COMPONENTS SHOULD BE ADEQUATELY PREHEATED BEFORE SOLDERING.
3. TERMINATION FINISH IS 100% TIN.
4. OPERATING TEMPERATURE TEMP: $-40^{\circ}\text{C} \sim +125^{\circ}\text{C}$ (INCLUDING SELF-HEATING)
5. COSMETIC SPECIFICATION REFER TO WI-QA-124.

Z vs. FREQUENCY
IMPEDANCE UNDER DC BIAS

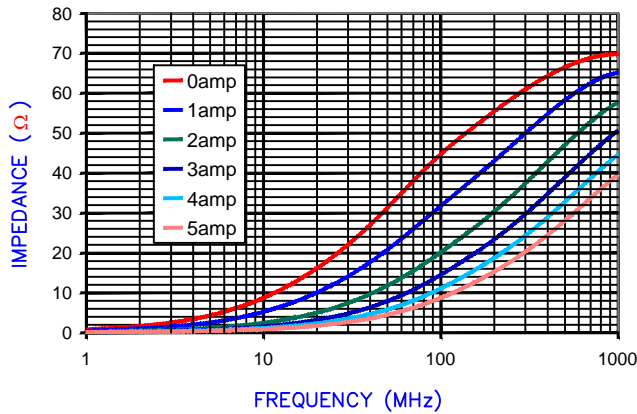

LAND PATTERNS FOR REFLOW SOLDERING

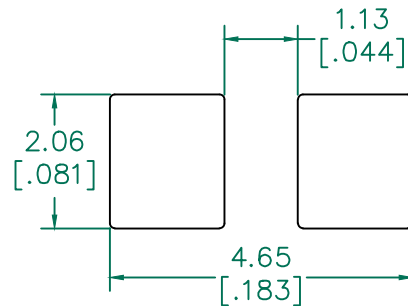

(For wave soldering, add 0.762 [.030] to this dimension)

RECOMMENDED SOLDERING CONDITIONS

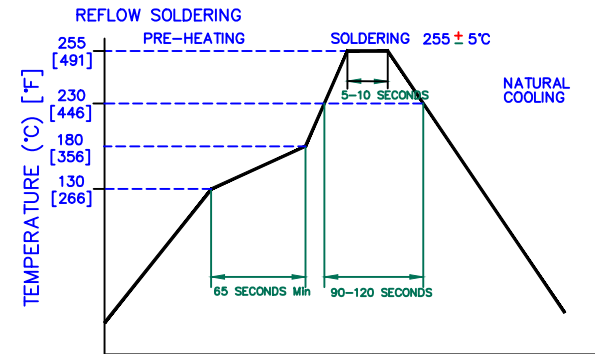

|Z|, R, AND XL vs. FREQUENCY

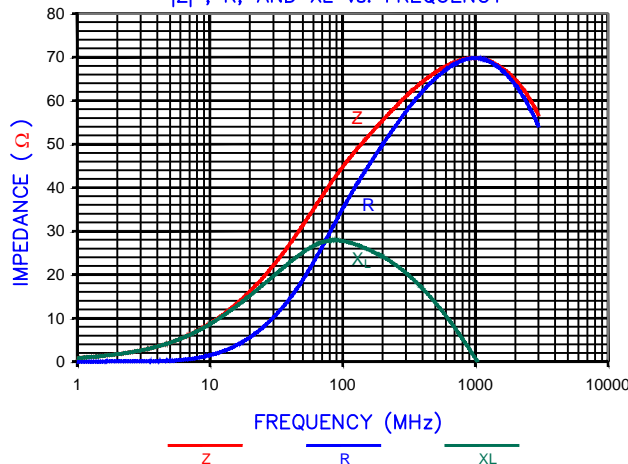

DIMENSIONS ARE IN mm [INCHES]				This print is the property of Laird Tech. and is loaned in confidence subject to return upon request and with the understanding that no copies shall be made without the written consent of Laird Tech. All rights to design or invention are reserved.		
D	ADD OPERATING TEMPERATURE UPDATE LAIRD LOGO AND REFLOW CURVE	08/05/13	QU	PROJECT/PART NUMBER:	REV	PART TYPE:
C	UPDATE COMPANY LOGO & ROHS SYM.	01/17/08	JRK	HI1206T500R-10	D	CO-FIRE
B	ADD ROHS SYMBOL AND NOTE 3	10/01/04	JRK	DATE:	SCALE:	SHEET:
A	ORIGINAL DRAFT	03/02/04	JRK	03/02/04	NTS	1 of 1
REV	DESCRIPTION	DATE	INT	CAD #	TOOL #	
				HI1206T500R-10-D	-	