

CY8CKIT-147 PSoC® 4100PS PROTOTYPING KIT QUICK START GUIDE

Block Diagram

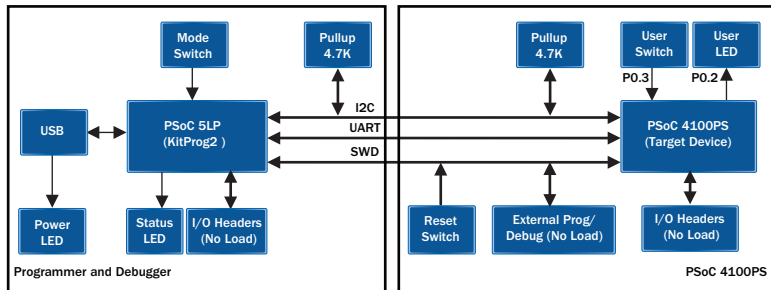

Code Example Operation

- Power the PSoC 4100PS Prototyping board by plugging the PCB USB connector (J8) to your computer.
- Amber LEDs, LED3 (Status LED) and LED2 (Power LED) turns ON.
- Blue LED, LED1 (User LED) starts glowing with breathing effect.

Note: For information on KitProg2 mode switching, refer the Kit Guide.

For more information, visit: www.cypress.com/CY8CKIT-147

Pinout Description

PSoC 5LP

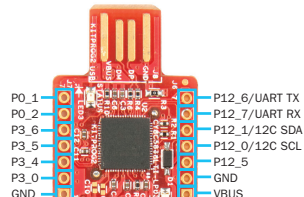

PSoC 4100PS

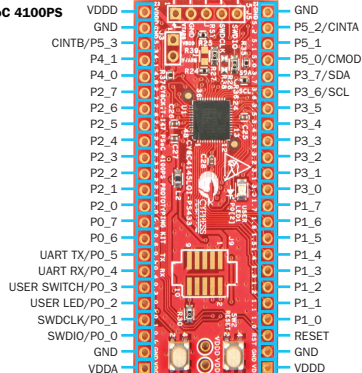

Design the way you think!



Cypress Semiconductor

CY8CKIT-147 PSoC® 4100PS Prototyping Kit



Contents under the label