

UNCONTROLLED DOCUMENT

PART NUMBER
CCL-CRS10R/G

REV.
G

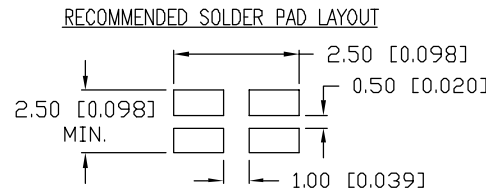
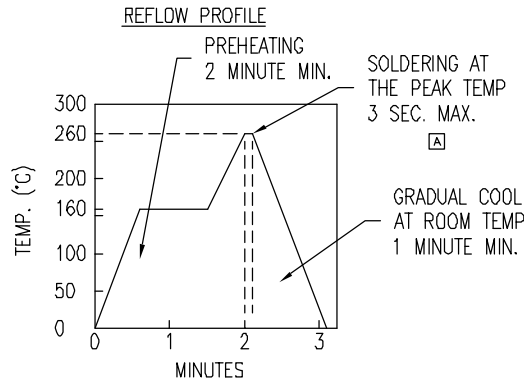
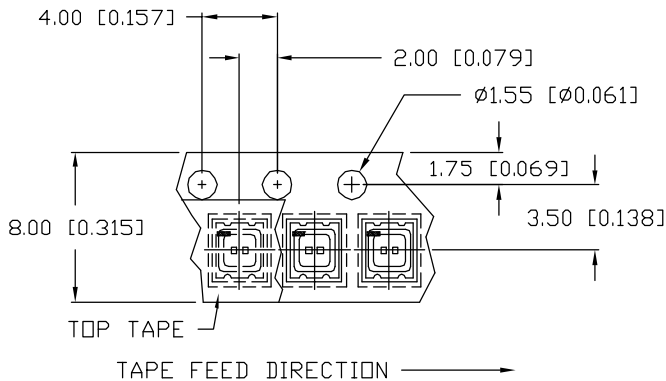
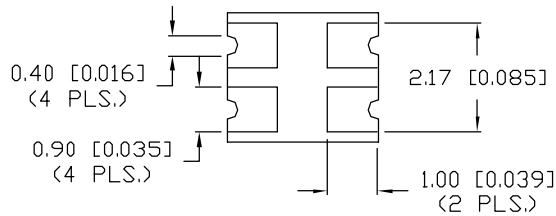
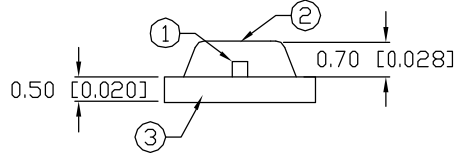
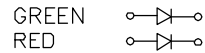
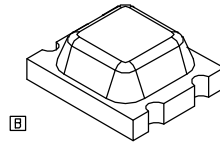
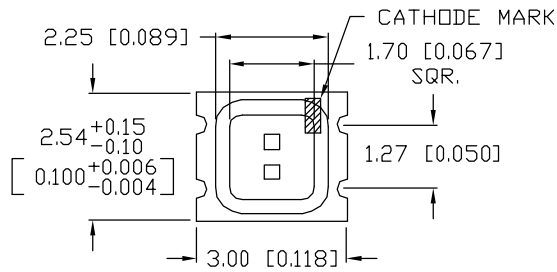

NOTES:

- PART SUPPLIED ON SUPER 8 TAPE AND REEL, 3,000 PIECES PER REEL.
- THE CATHODE IS ORIENTED TOWARDS THE TAPE SPROCKET HOLE.
- WHITE CERAMIC CARRIER.

CAUTION: MOISTURE SENSITIVE DEVICE
PER JEDEC LEVEL 4 STANDARDS

REV.	E.C.N. NUMBER AND REVISION COMMENTS	DATE
A	REDRAWN.	4.27.93
B	CORRECTED WAVELENGTH.	1.14.94
C	UPDATED SOLDER SPECS.	9.27.94
D	E.C.N. #10390 & #10BRDR & REDRAWN.	10.2.98
E	E.C.N. 10484. ADDED SOLDER PROFILE	12.11.98
F	E.C.N. #10695. & REDRAWN IN 3D.	1.12.01
G	E.C.N. #10967.	3.14.03

ELECTRO-OPTICAL CHARACTERISTICS $T_A=25^\circ\text{C}$ $I_f=20\text{mA}$					
PARAMETER	MIN	TYP	MAX	UNITS	TEST COND
PEAK WAVELENGTH		635 (RED)		nm	
		565 (GREEN)		nm	
FORWARD VOLTAGE (R/G)		2.0/2.2	2.5/2.6	V_f	
REVERSE VOLTAGE	4.0			V_r	$I_r=100\mu\text{A}$
AXIAL INTENSITY (R/G)		4/12		mcd	$I_f=20\text{mA}$
VIEWING ANGLE		180		2x theta	
EMITTED COLOR:	RED/GREEN				
EPOXY LENS FINISH:	WATER CLEAR				

LIMITS OF SAFE OPERATION AT 25°C PER CHIP			
PARAMETER	COLORS	MAX	UNITS
PEAK FORWARD CURRENT*		100	mA
STEADY CURRENT		25	mA
POWER DISSIPATION		65	mW
DERATE FROM 25°C		-0.33	mW/°C
OPERATING TEMP.		-30 TO +75	°C
STORAGE TEMP.		-40 TO +85	°C

* $t < 10\mu\text{s}$

SOLDER HEAT PROOF TEST:	DIPPING FOR 5 SEC. AT 250°C, 2 TIMES.
THERMAL SHOCK TEST:	15 MIN. AT +90°C, AND 15 MIN. AT -30°C, 25 CYCLES.
VIBRATION TEST:	50Hz, FULL AMPLITUDE WIDTH; 1.5mm, 2 HOURS VERTICALLY AND HORIZONTALLY, RESPECTIVELY.
MOISTURE TEST:	$T_a=60^\circ\text{C}$, $R_h=90\%$, 1,000 HOURS.
IRON SOLDERING:	20W IRON (SHARP TIP), 280-320°C, 5 SEC. MAX.,
SOLDER DIP METHODE:	TEMP. IS 240-260°C AND TIME IS WITHIN 10 SEC.
RE-FLOW SOLDERING:	SEE CHART.

UNCONTROLLED DOCUMENT

*UNLESS OTHERWISE SPECIFIED TOLERANCES PER DECIMAL PRECISION ARE: X=±1 (±0.039), X.X=±0.5 (±0.020), X.XX=±0.25 (±0.010), X.XXX=±0.127 (±0.005). LEAD SIZE=±0.05 (±0.002), LEAD LENGTH=±0.75 (±0.030). MIN=+DECIMAL PRECISION MAX.=+0.00-DECIMAL PRECISION

REV.	PART NUMBER
G	CCL-CRS10R/G

3.0mm X 2.5mm CERAMIC SURFACE MOUNT LED,
RED & GREEN LEDS, WATER CLEAR LENS.

CONFIDENTIAL INFORMATION
THE INFORMATION CONTAINED IN THIS DOCUMENT IS THE PROPERTY OF LUMEX INC. EXCEPT AS SPECIFICALLY AUTHORIZED IN WRITING BY LUMEX INC., THE HOLDER OF THIS DOCUMENT SHALL KEEP ALL INFORMATION CONTAINED HEREIN CONFIDENTIAL AND SHALL PROTECT SAME IN WHOLE OR IN PART FROM DISCLOSURE AND DISSEMINATION TO ALL THIRD PARTIES.

RELIABILITY NOTE
OUR MANY YEARS OF EXPERIENCE DATA ACCUMULATION INDICATE THAT SOLDER HEAT IS A MAJOR CAUSE OF EARLY AND FUTURE FAILURE. PLEASE PAY ATTENTION TO YOUR SOLDERING PROCESS.



290 E. HELEN ROAD
PALATINE, IL 60067-6976
PHONE: +1.847.359.2790
US WEB: www.lumex.com
TW WEB: www.lumex.com.tw

DRAWN BY: CT	CHECKED BY:	APPROVED BY:	DATE: 4.11.92
			PAGE: 1 OF 1
			SCALE: N/A