

600 W half-bridge LLC evaluation board

EVAL_600W_12V_LLC_CFD7

[Di Domenico Francesco \(IFAT PMM ACDC AE\)](#)
[Zechner Florian \(IFAT PMM ACDC AE\)](#)



Table of contents

1

General description

2

Efficiency results

3

Design concept

Table of contents

1

General description

2

Efficiency results

3

Design concept

General description

The "EVAL_600W_LLC_12V_CFD7" - evaluation board shows how to design a half-bridge LLC stage of a server SMPS with the target to meet **80+ Titanium Standard** efficiency requirements. For this purpose the following components have been used: latest [600 V CoolMOS™ CFD7](#) SJ MOSFET technology ([IPP60R170CFD7](#)) on the primary side and OptiMOS™ 40 V low voltage power MOSFET ([BSC010N04LS](#)) in the synchronous rectification secondary stage, in combination with quasi-resonant CoolSET™ ([ICE2QR2280Z](#)), EiceDRIVER™ Compact 2EDL hi-low side driver ([2EDL05N06PF](#)), 2EDN EiceDRIVER™ low side gate Driver ([2EDN7524F](#)) and analog LLC controller ([ICE2HS01G](#)).

Summary of features:

- › Output voltage: 12 V
- › Output current: 50 A
- › Peak efficiency @ 50% load >97.4%
- › Efficiency @ 10% load >94%

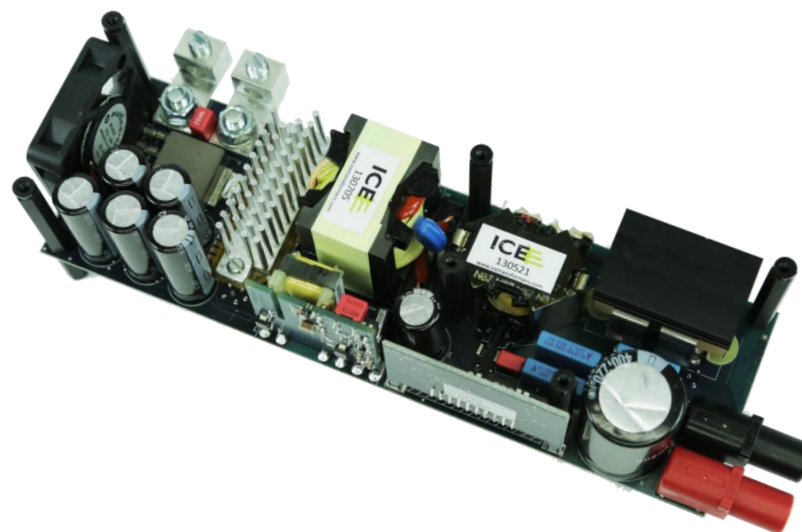

The following variants are available:

- › 600 W 12 V LLC **analog** version with CoolMOS™ CFD7, [EVAL_600W_12V_LLC_CDF7](#)
 - › Control card kit „from analog to digital“ can be ordered additionally [KIT_600W_LLC_DI_CTRL](#)
 - › Additional analog control card [KIT_600W_LLC_AN_CTRL](#)

Example of system understanding: Infineon demo solution for Titanium HV DC-DC stage

Half-bridge LLC with synchronous rectification in center tap configuration

V_{in}	350-410 V _{DC}
V_{in_nom}	380 V _{DC}
V_{out_nom}	12 V _{DC}
I_{out}	50 A
P_o	600 W
$f_{res}=f_0$	157 kHz
f_{min}	90 kHz
f_{max}	210 kHz
Transformer turns ratio	16:1
C_r	66 nF
L_r	15.5 μ H
L_m	195 μ H

Primary HV MOSFETs

- > **CoolMOS™ IPP60R170CFD7**
Reduced gate charge (Q_g)
- > Reduced E_{off}
- > High body diode ruggedness

SR MOSFETs

- > **OptiMOS™ BSC010N04LS**
New generation
- > Best FOM $R_{DS(on)} \times Q_g$
- > Best FOM $R_{DS(on)} \times Q_{oss}$

HB gate driver IC

2EDL05N06PF
Non isolated LS gate drive
 2EDN7524F
LLC controller
 Analog ICE2HS01G

Bias QR flyback controller

ICE2QR2280Z

SR MOSFETs

BSC010N04LS

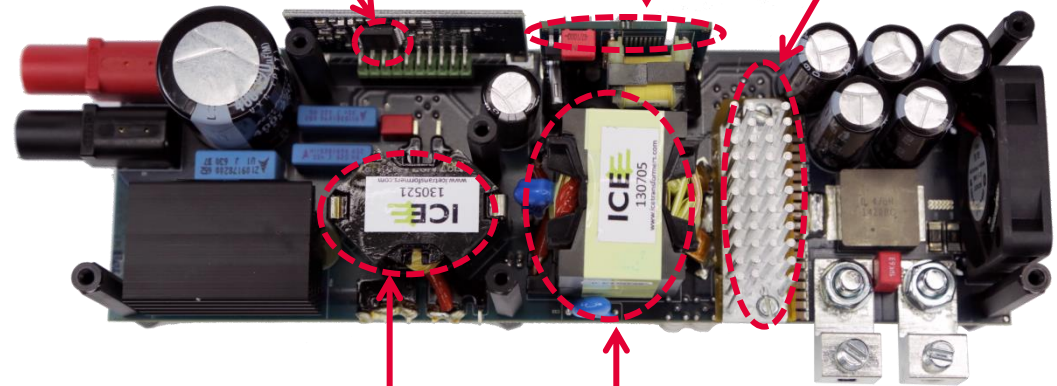

Resonant inductor

RM12 core

Transformer

PQ35/35 core

Control card boards

Infineon's 600 W LLC evaluation board delivered with analog control, digital control card kit online available

Analog

With ICE2HS01G

- > Resonant mode controller for half-bridge LLC resonant converter with synchronous rectification drives
- > Driving signal for synchronous rectification which support full operation of half-bridge LLC resonant converter
- > 20-pin DSO package
- > 30 kHz to 1 MHz switching frequency
- > 50% duty cycle for both primary and secondary gate drives
- > Adjustable dead time with high accuracy

Order code: [KIT 600W LLC AN CTRL](#)

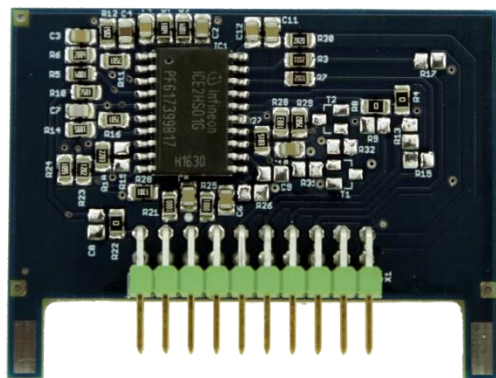

Digital (on request)

With XMC4200-Q48K256 AB

- > ARM® Cortex®-M4, 80 MHz, incl. single cycle DSP MAC and floating point unit (FPU)
- > 8-channel DMA + dedicated DMA for USB
- > USB 2.0 full-speed device
- > CPU Frequency: 80 MHz
- > eFlash: 256 kB including hardware ECC
- > 40 kB SRAM
- > Package: PG-LQFP-48

Order code: [KIT 600W LLC DI CTRL](#)

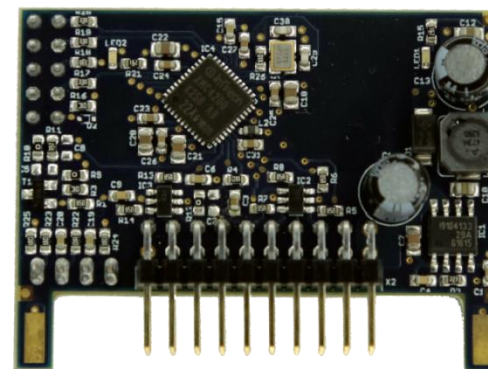

PCB boards layout: main power board and control and bias daughter boards

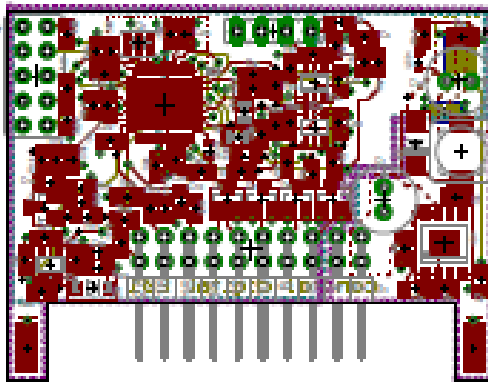
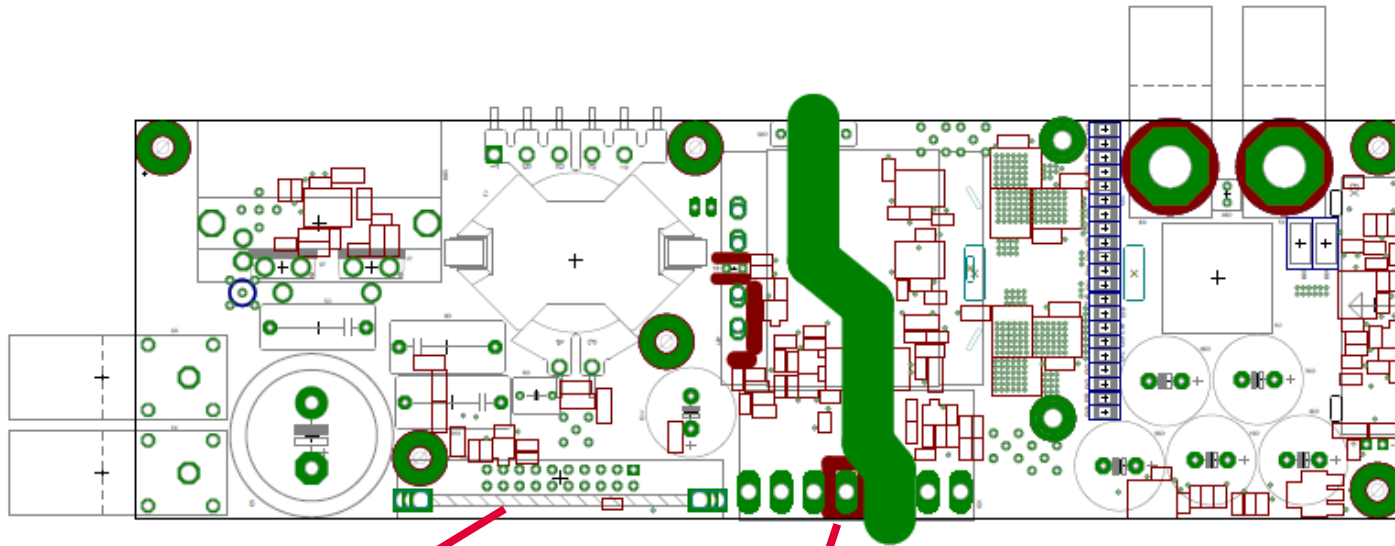

Controller board

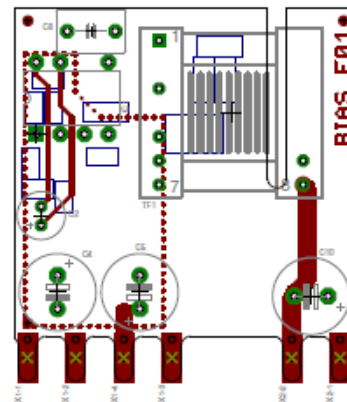

Bias board

> Power density > 20 W/inch³

Bias board schematic

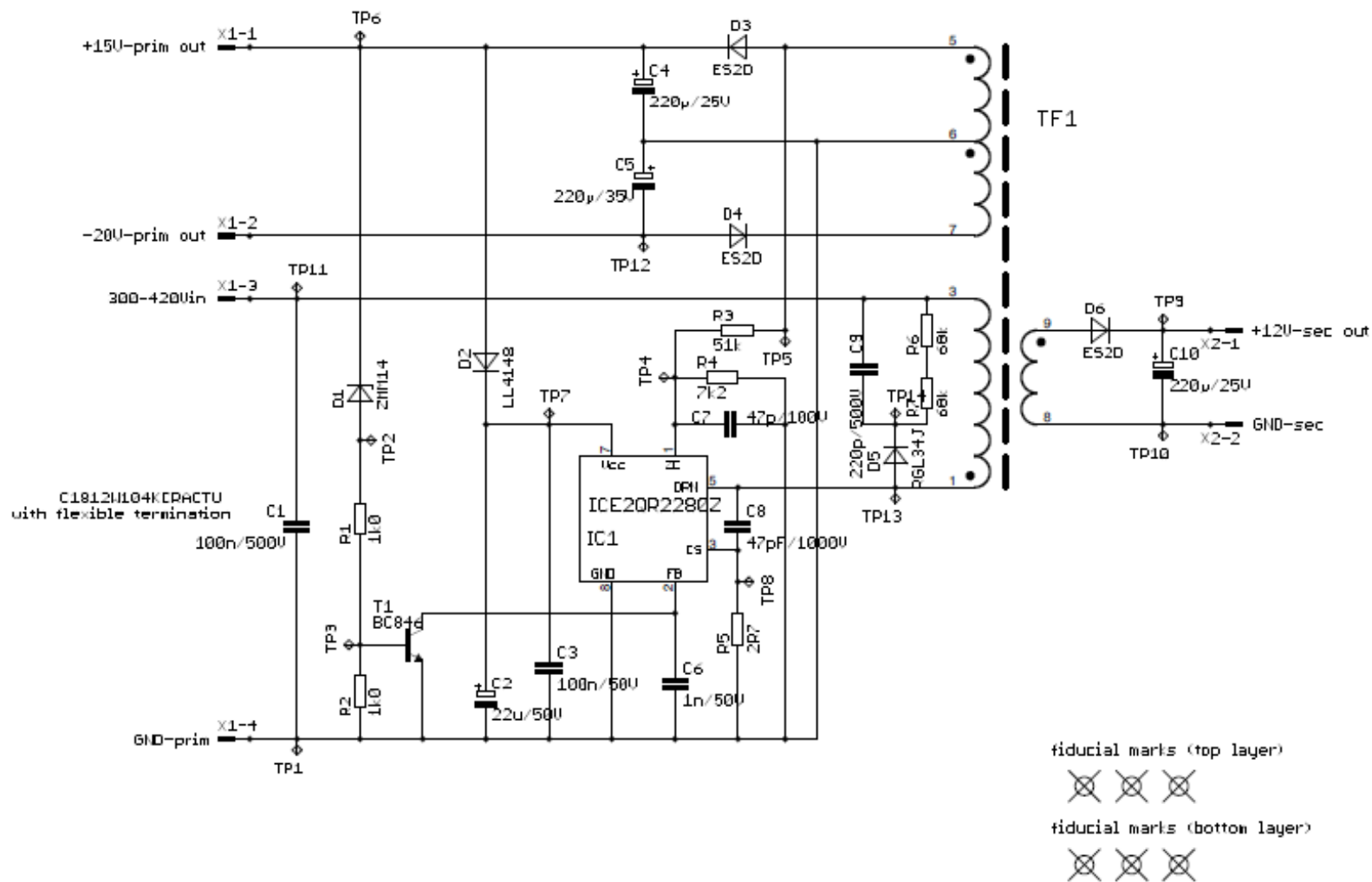

Analog control board schematic

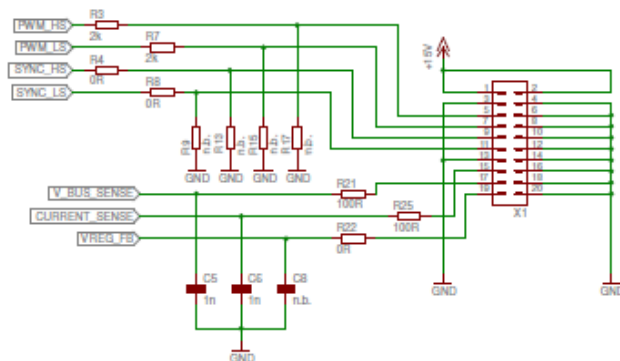

copper area for fixing pcb by soldering

fiducial marks on top layer

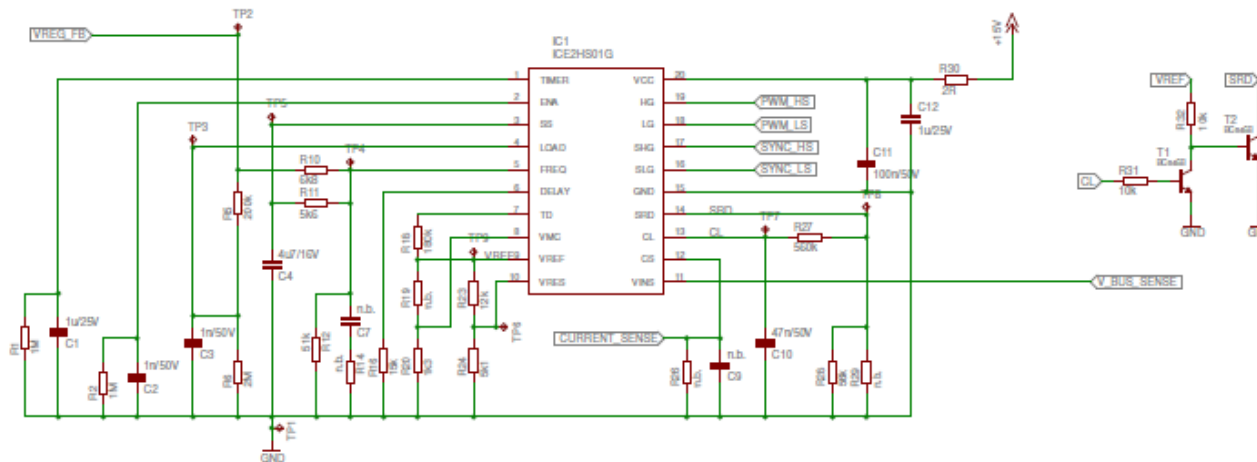

Table of contents

1

General description

2

Efficiency results

3

Design concept

Automated efficiency measurement

Combination of converter design (resonant tank, transformer) and proper HV device election

Proper selection of SR LV device and secondary side design

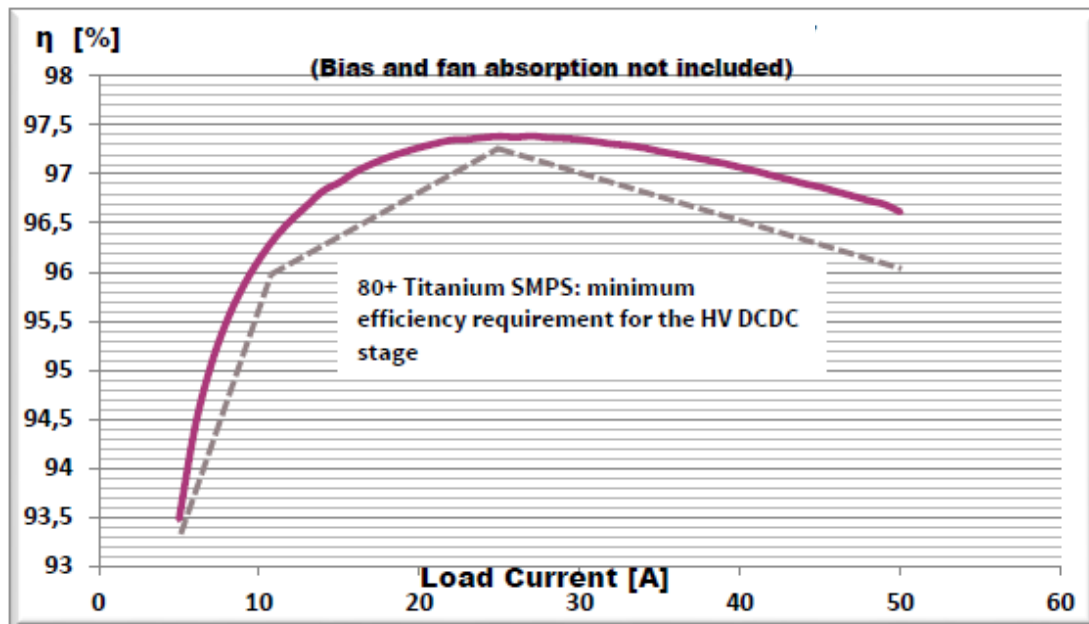

Output voltage: 12 V_{DC}
Output current: 50 A

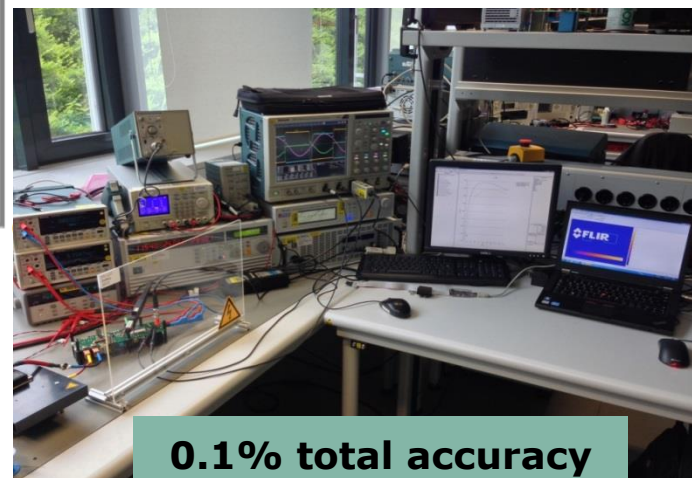

Table of contents

1 General Description

2 Efficiency Results

3 Design Concept

Design procedure: Input data

$$n = \frac{V_{in_nom}}{2 \cdot V_{out_nom}}$$

$$M_{\min} \equiv K_{\min}(Q, m, F_x) = \frac{n \cdot V_{o_min}}{V_{in_max} / 2}$$

$$M_{\max} \equiv K_{\max}(Q, m, F_x) = \frac{n \cdot V_{o_max}}{V_{in_min} / 2}$$

Resonant tank components and related resonant frequencies

- › $n = V_{in_nom} / (2 \times V_o) = 380 / (2 \times 12) \approx 16$
- › $L_m = 195 \mu H$
- › $L_r = 15.5 \mu H$
- › $L_n = L_m / L_r = 12.5$
- › $C_r = 66 nF$

$$f_o = \frac{1}{2\pi \cdot \sqrt{L_r \cdot C_r}} = 157 kHz$$

$$f_p = \frac{1}{2\pi \cdot \sqrt{(L_r + L_m) \cdot C_r}} = 42.7 kHz$$

Gain curves

DC - gain curve (600 W LLC hardware revision CFD7)

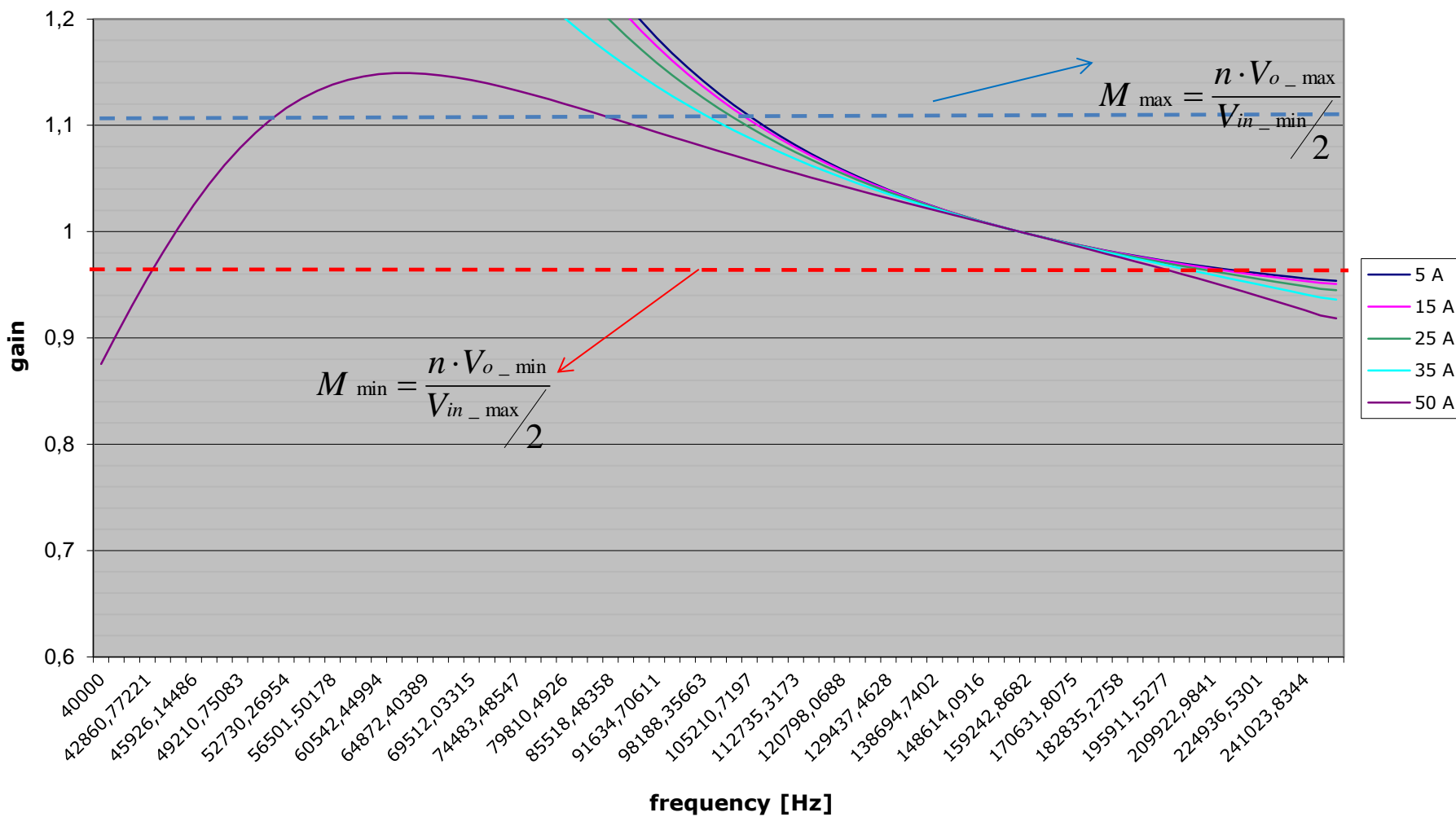

Energy related calculations (Ref. IPP60R170CFD7 device parameters)

$$I_{mag_min} = \frac{2 \cdot \sqrt{2}}{\pi} \cdot \frac{n \cdot V_o}{2\pi \cdot f_{sw_max} \cdot L_m} = 0.672 \text{ A}$$

$$E_{nres_min} = \frac{1}{2} \cdot (L_m + L_r) \cdot I_{mag_min}^2 = 95.1 \mu\text{J}$$

$$E_{ncap_max} = \frac{1}{2} \cdot (2C_o(er)) \cdot V_{DS_max}^2 \approx 9 \mu\text{J}$$

$\Rightarrow E_{nres_min} > E_{ncap_max}$

$Q_{oss}, I_{mag,pk}, t_{dead,min}, t_{ecs}$ relationship

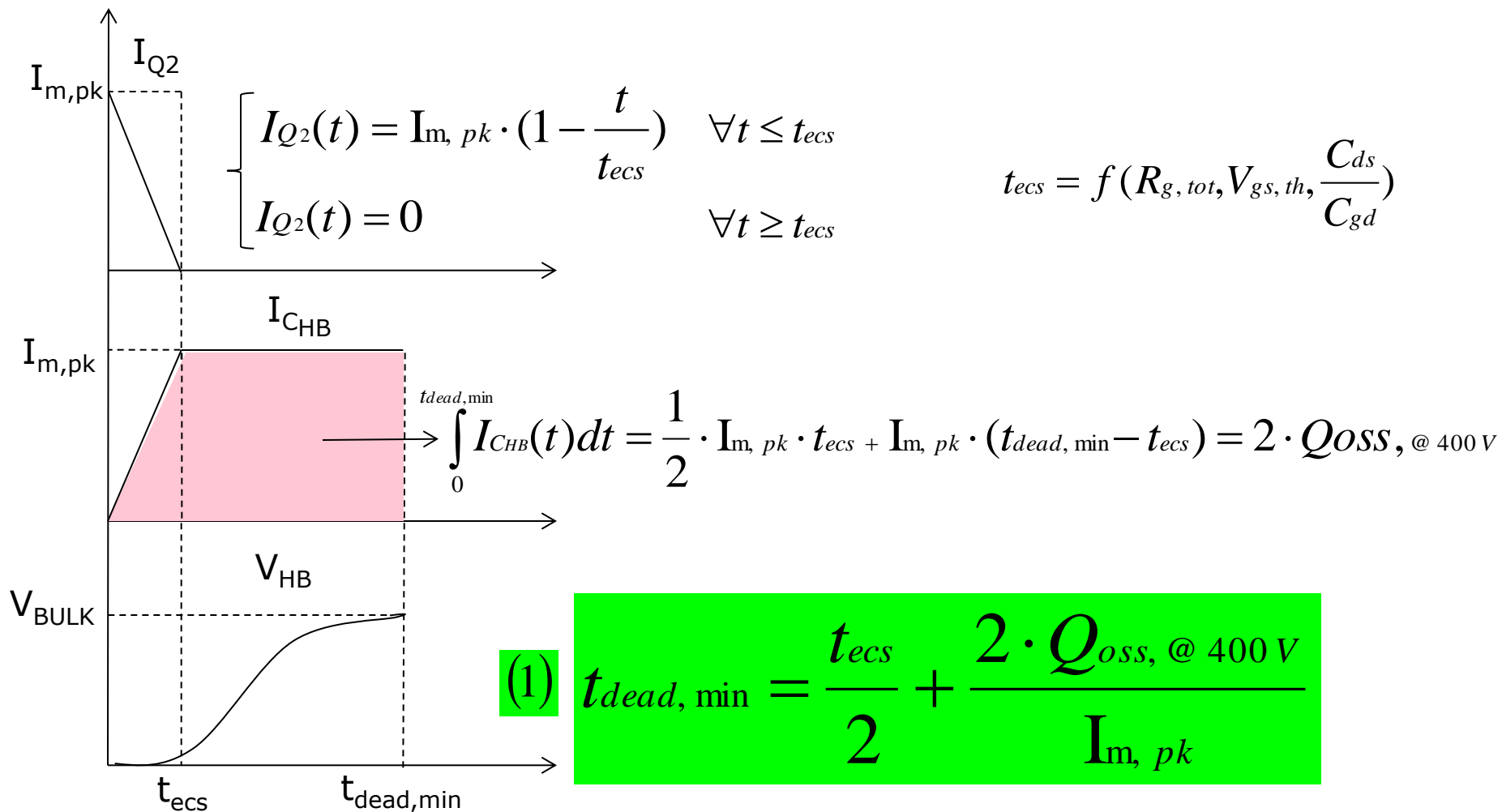

Time related calculations (Ref. IPP60R170CFD7 device parameters)

$$I_{mag_min} = \frac{2 \cdot \sqrt{2}}{\pi} \cdot \frac{n \cdot V_o}{2\pi \cdot f_{sw_max} \cdot L_m} = 0.672 \text{ A}$$

$$I_{mag_max} = \frac{2 \cdot \sqrt{2}}{\pi} \cdot \frac{n \cdot V_o}{2\pi \cdot f_{sw_min} \cdot L_m} = 1.66 \text{ A}$$

$$t_{dead, min} = \frac{t_{ecs}}{2} + \frac{2 \cdot Q_{oss, @ 400V}}{I_{mag, max}} \approx 130 \text{ nsec}$$

$$t_{dead, max} = \frac{t_{ecs}}{2} + \frac{2 \cdot Q_{oss, @ 400V}}{I_{mag, min}} \approx 311 \text{ nsec}$$

Main transformer structure: PQ35/35 core with TDK PC95 ferrite material

Wind.	Conductor	N°. of Turns	Polarity	Output pin	Winding layer	N°. layer	Sleeves				Notes
							Col.	Ref. M.L.	Total length mm.	Free length mm.	
N1a	2xLitz 90x0.10 Ref.3	0 8	+	2-3 *	8	1	Re	8	20	/	2 wires in 1 sleeve.
							Re	8	20	/	
Insulation: 3 turns of polyester adhesive tape Ref.6											
N2 N3	Copper foil 0.50x0.20 Ref.4	0 1	+	A B C	1	1	/	/	/	/	
Insulation: 1 turns of polyester adhesive tape Ref.6 + 1 piece as showed in pictures											
N1b	2xLitz 90x0.10 Ref.3	0 8	+	* 4-5	8	1	Re	8	20	/	2 wires in 1 sleeve. Don't need correspondence
Insulation: 3 turns of polyester adhesive tape Ref.6											

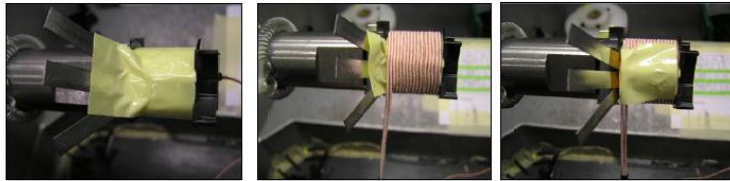

Insert piece of tape after the insulation of N2-N3. Wind N1b. Refold tape, block and connect the wires to pin

Positioning coilformer – pin side

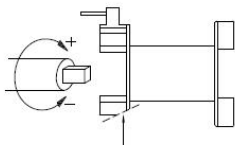

Smooth the inner part

Bottom view

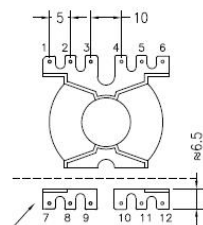

Remove

Electrical diagram

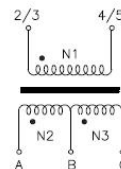

Copper foil preparation

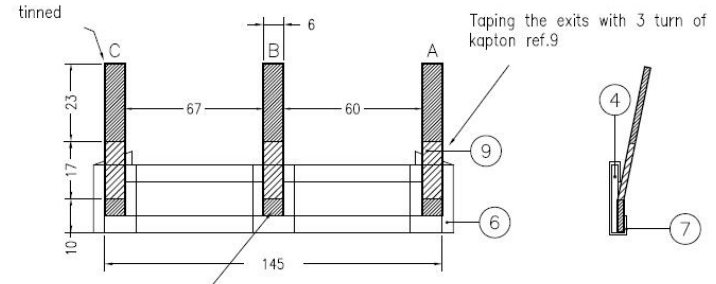

Solder the exits A-B-C ref. 5 on copper foil ref.4

Insulate the foil with tape ref.7 and the welding with tape ref.6

finished part



REV	APPR DATE	REF MOD	DESCRIPTION OF MODIFICATION	EDITING	CHECKING AND APPROVAL
02	21.07.15		Inserted label and pictures	C. Picciani	D. Di Giorgio
01	24.01.14		Release	C. Picciani	D. Di Giorgio
TRANSFORMERS DESCRIPTION Trasformatore PQ35/35 600W LLC converter (130705)					
Mod.	DOCUMENT TYPE	CODE	REVISION	RELEASE DATE	PAGE
AQ 05.09	P.F.	8065.0703.001	02	24.01.14	1of2

Resonant choke: RM12 core, material N87

Wind.	Conductor type	N. of windings	R output pin	Winding Layer	N. of Layer	Tube			Notes
						Color	Ref.	Length mm	
N1	Litz 120x0.10 Ref. 4	0 9	+ 7+8+9 10+11	9	1	/ Red	/ 6	/ 20	Perpendicular crossing on tape ref.5

Insulation: 2 turns polyester tape Ref.5

Bill of materials	
Ref.	Description
1	Coil Former RM12 12pins (B65816-C1512-T1 Epcos mat.Valox420 E45329)
2	Ferrite core RM12 gap 1.1mm (B65815-R87 Epcos)
3	RM12 clamp (B65816-A2002 Epcos)
4	Litz wire 120x0.100mm G1 (155°C E125660 or equivalent)
5	Polyester adhesive tape H=16mm thickness 0.06mm (P31 E178430 or equivalent)
6	Tube glass/silicone Ø1.5mm 4KV 20mm (GVES2500 E311983 or equivalent)
7	Activator for epoxy resin (IN1005 or equivalent)
8	Epoxy resin (36T or equivalent)
9	PVC label 24x12mm
10	Insulating varnish classH (AC43 E317427 or equivalent)
11	Polyestere label 4.7x14mm (7816 MH16411 or equivalent)

Winding rotation	Bottom View	Electrical drawing

Assembling

* Serial number
ICEAANNNN * (11)

Fix core/coilformer with ref. 7+8

Varnish with ref.10

Dimensions in millimeter
RoHS compliant

Electrical test			
N°.	Test type	Test conditions	Limits
1	Inductance	7+8+9-10+11 @ 10 kHz - 100 mV	from 11.9 to 16.1 µH

REV	Appr. date	Ref. Mod.	Modification description	Editing	Checked and Approved
02	21.07.15		Inserted new label	C. Picciani	D. Di Giorgio
01	23.01.14		Release	C. Picciani	D. Di Giorgio

DESCRIPTION	INDUCTANCE	REVISION	EMISSION DATE	PAGE
Inductance RM12 LLC resonant choke (130521)				
Mod. AQ 05.09	P.F.	8017.0901.012	02	23.01.14

Evaluation board EVAL_600W_12V_LLC_CFD7





Technical Material

- > Application Notes
- > Simulation Models
- > Datasheets
- > PCB Design Data

> [EVAL_600W_12V_LLC_CFD7](#)

Evaluation Boards

- > Evaluation Boards
- > Demoboards
- > Reference Designs

> www.infineon.com/evaluationboards

Videos

- > Technical Videos
- > Product Information Videos

> www.infineon.com/mediacenter

Support Online tools and services



The screenshot shows the Infineon website header with the following elements:

- Infineon logo
- Navigation menu: Products, Applications, **Tools** (highlighted with a red box and '3'), About Infineon, Careers
- Utility links: **Newsletter** (highlighted with a red box and '1'), Contact, **Where to Buy** (highlighted with a red box and '2'), English, Login
- Search bar with a magnifying glass icon

The main content area features a large image of a city skyline at night. Overlaid on the right side of the image is a teal box with the text:

Lighting

New LED controller enables low-wattage luminaire designs
August 26th 17:00 CEST

[Register Now!](#) >

Navigation arrows (< and >) are visible on the left and right sides of the image. Below the image is a row of five small circular indicators.

- 1 **Subscribe to Newsletter**
- 2 **Where to Buy**
- 3 **Tools, Finders and Selectors**
- 4 **Support**

The screenshot shows the website's navigation menu with the following structure:

- Products** (highlighted with a red box and '4')
 - Applications
 - Tools
 - Support** (highlighted with a red box)
 - Technology
- Power**
 - Automotive System IC
 - ESD & EMI
 - Microcontroller
 - RF & Wireless Control
 - Security IC
 - Sensor
 - Smart Card IC
 - Interface
 - Transistor & Diode
- Power Overview**
 - Power MOSFET
 - IGBT
 - Smart Low-Side & High-Side Switches
 - Linear Voltage Regulator
 - DC-DC Converter
 - LED Driver | Lighting ICs
 - Silicon Carbide (SiC)
 - High Power Thyristors & Diodes
 - Motor Control & Gate Driver
 - AC-DC Supply

News & Tweets



Part of your life. Part of tomorrow.

